

# **INSTRUCTION MANUAL** Ver 1.4

Megapixel PTZ Camera

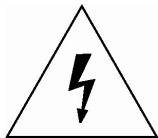

### **CAUTION**

**RISK OF ELECTRIC SHOCK  
DO NOT OPEN**



**CAUTION : TO REDUCE THE RISK OF ELECTRICAL SHOCK, DO NOT OPEN THE COVERS.  
NO USER SERVICEABLE PARTS INSIDE.  
REFER SERVICING TO QUALIFIED SERVICE PERSONAL**



This lightning flash with arrowhead symbol is intended to alert the user to the presence of un-insulated "dangerous voltage" within the product's enclosure that may be of sufficient magnitude to constitute a risk of electric shock to persons.



This exclamation point symbol is intended to alert the user to the presence of important operating and maintenance (servicing) instructions in the literature accompanying the appliance.



This Device complies with Part 15 of the FCC Rules. Operation is subject to the following two conditions:

- (1) This device may not cause harmful interface, and
- (2) This device must accept any interference received, including interference that may cause undesired operations.





---

## Important Safety Guide

### 1. Read, heed and follow all the Instructions

Read all the safety and operating instructions before using the product.

### 2. Keep this manual

Keep this manual for reference in future.

### 3. Attachments / Accessories

Use only the attachments or accessories specified by the manufacturer.

### 4. Installation

- Do not install near any heat resources such as radiators, heat registers, stoves, or other apparatus including amplifiers that produce heat. Improperly installed product may fall, cause serious injury to a child or adult and damage the product.
- Do not block any ventilation holes or openings. Install in accordance with the manufacturer's instructions.
- Use only with the cart, stand, tripod, bracket, mounting devices, or table specified by the manufacturer.
- Installation should be done only by qualified personnel and conform to all the instructions by the manufacturer.
- Refer all servicing to qualified service personnel.
- Unless the product is specifically marked as IP67, more than IP67 or confirmed by the manufacturer, it is designed for indoor use only and it must not be installed where exposed to rain and moisture.
- Do not load on the product.
- Use stainless steel hardware to fasten the mount.
- To prevent damage from water leakage when installing a mount outdoors on a roof or wall, apply sealant properly around holes.
- These servicing instructions are for use by qualified service personnel only. To reduce the risk of electric shock, do not perform any servicing other than that contained in the operating instructions unless you are qualified to do so.
- Use only replacement parts specified by the manufacturer.

### 5. Power source

This product should be operated only from the type of the power source indicated on the marking label. **It is mandatorily recommended to use a UPS in order to be prepared for a power failure.**



---

**Caution****❑ Operating**

- Before using, make sure that the power supply and others are properly installed.
- While operating, if any abnormal condition or malfunction is observed, stop using the product immediately and then contact your local dealer.

**❑ Handling**

- Do not disassemble or tamper with the parts inside the product.
- Do not drop or subject the product to shock and vibration as this can damage the product.
- Care must be taken when you clean the clear dome cover. Especially, scratch and dust will ruin the quality of the product.

**❑ Installation and Storage**

- Do not install the product in areas of extreme temperature, which exceed the allowable range.
- Avoid installing in humid or dusty places.
- Avoid installing in places where radiation is present.
- Avoid installing in places where there are strong magnetic fields and electric signals.
- Avoid installing in places where the product would be subject to strong vibrations.

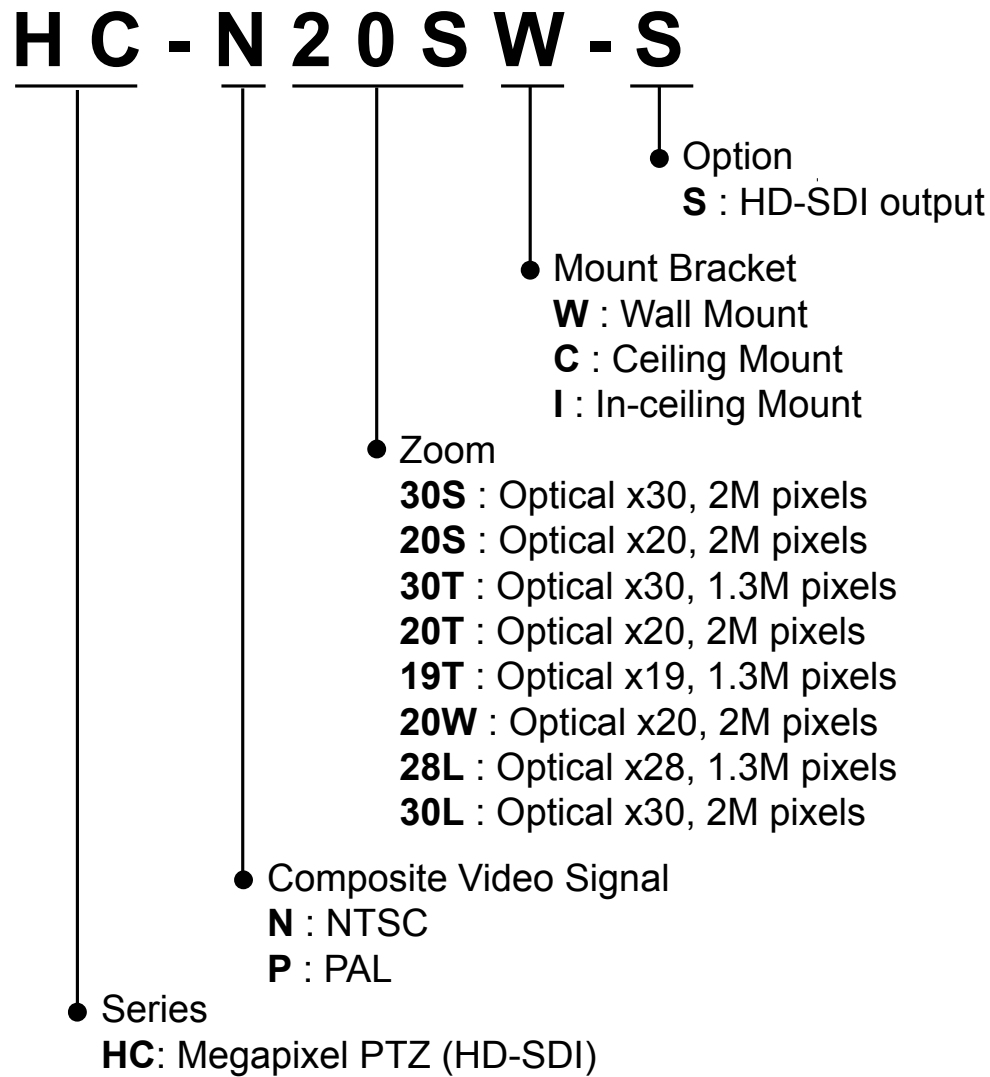

<b>① Introduction</b>	
Model Code	6
Features	7
Package Components	10
Main Part Description	12
<b>② Installation</b>	
DIP Switch Setup	13
Installation with Ceiling Mount Bracket	15
Installation with Wall Mount Bracket	16
Wiring and Cabling	18
<b>③ Operation</b>	
Check Point before Operation	22
Check Points for Preset and Pattern Function before Operation	22
OSD Menu	23
Reserved Preset (Hot Keys)	23
Preset	24
Swing	24
Pattern	25
Group	26
Other Functions	26
OSD Display	28
<b>④ OSD Menu</b>	
Quick Programming Guide	29
Video Setup	29
Privacy Mask Setup	42
PTZ Setup	44
Action Setup	46
Preset Setup	47
Swing Setup	49
Pattern Setup	50
Group Setup	52
Alarm Trigger Setup	53
Schedule Setup	54
OSD Setup	55
System Setup	57
Time Setup	60
Password Setup	61
<b>⑤ Specifications</b>	62
Dimension	72

**Model Code**

## Features

### □ Powerful Zoom Camera & Setup Options

- Image Sensor : 1/2.8" Exmor CMOS Image Sensor, 3 Mega pixels (30S model)  
1/2.8" Exmor CMOS Image Sensor, 3 Mega pixels (20S model)  
1/4" PS CMOS Image Sensor, 1.3 Mega pixels (30T model)  
1/3" PS CMOS Image Sensor, 2 Mega pixels (20T model)  
1/3" PS CMOS Image Sensor, 1.3 Mega pixels (19T model)  
1/3" Panasonic CMOS Image Sensor, 2 Mega pixels (20W model)  
1/4" CMOS Image Sensor, 1.3 Mega pixels (28L model)  
1/2.8" CMOS Image Sensor, 3 Mega pixels (30L model)
- Zoom : ×30 Optical Zoom, ×12 Digital Zoom (30S model)  
×20 Optical Zoom, ×12 Digital Zoom (20S model)  
×30 Optical Zoom, ×12 Digital Zoom (30T model)  
×20 Optical Zoom, ×8 Digital Zoom (20T model)  
×19 Optical Zoom, ×16 Digital Zoom (19T model)  
×20 Optical Zoom, ×12 Digital Zoom (20W model)  
×28 Optical Zoom, ×12 Digital Zoom (28L model)  
×30 Optical Zoom, ×12 Digital Zoom (30L model)
- Day & Night, Privacy Mask
- WDR function (30S, 20S, 30T, 20W, 28L, 30L models)
- HLC function (30T, 20T, 19T models)
- NR (Noise Reduction) Function
- Defog Function (20W model)
- Image Stabilization Function (30S, 30T, 20T, 19T, 28L, 30L models)
- Various Focus Mode : Auto-Focus, Manual Focus, Semi-Auto Focus
- Various Setup Options in OSD Menu.

### □ HD-SDI and Composite Video Output

- Raw(Non-Compressed) Digital HD-SDI(High Definition Serial Digital Interface) Output (HDcctv v1.0, 1.485Gb/s, SMPTE 292M Standard)
- HD-SDI Video Transmission over Coaxial Cable.
- Simultaneous HD-SDI and Analogue(Composite) Video Output

### ❑ Powerful Pan/Tilt Functions

- MAX. 500°/sec High Speed Pan/Tilt Motion
- With the Vector Drive Technology, Pan/Tilt motions are accomplished along the shortest path. As a result, the time to target view is remarkably short and the video on the monitor is very natural in monitoring.
- With the Micro-Stepping Control Technology, the video looks very natural at high zoom magnification during a jog operation on a controller since the camera can be controlled by 0.05°/sec. Hence it is very easy to make the camera focus on desired target views at high zoom magnification. Additionally it is easy to make the camera focus on desired positions with zoom-proportional pan/tilt movement.

### ❑ RTC(Real Time Clock) Function

- Date and Time can be configured for Schedule Function
- With Backup Battery Function, Date and Time configuration should be kept up for a while, even though power is off

### ❑ Preset, Pattern, Swing, Group, Schedule, Privacy Mask and More...

- MAX. 209 Presets are programmable and each preset can have its own parameter values independently from the other presets.

For an example, refer to the below table.

Preset No.	White Balance	Auto Exposure	...	Label	Remarks
Preset 1	Case A	Case 3		“ENTRANCE”	
Preset 2	Case C	Case 5		“WAREHOUSE”	
...					
Preset 95	–	–	–	–	Reserved for OSD Menu
...					
Preset 255	Case K	Case 9		“TERRACE”	

- MAX. 10 sets of Swing are programmable. This function is that a camera moves repetitively between two preset positions at programmed speeds.
- MAX. 4 Patterns are programmable. This function is that a camera memorizes the path (mostly curve path) by the joystick of the controller and revives the trajectory operated by the joystick as closely as possible.
- MAX. 8 sets of Group are programmable. This function is that a camera memorizes the combination of Presets, Pattern and/or Swings sequently and runs Presets, Pattern and/or Swings repetitively. A Group can be combined upto 40 functions with any of Preset/Pattern/Swing.
- MAX. 8 Privacy Masks are programmable, not to intrude on any other’s privacy.



- MAX. 8 sets of Schedule are programmable. This function is that a camera runs a function such as Preset, Pattern, Swing or Group at an assigned time. Also this function can be run periodically by pre-defined schedules.

#### ❑ **PTZ(Pan/Tilt/Zoom) Control**

- With the RS-485 communication connection, MAX. 255 units of cameras can be connected to a single controller.
- Pelco-D or Pelco-P protocols can be selected as a control protocol in the current firmware version.

#### ❑ **OSD(On Screen Display) Menu**

- OSD menu is provided to display the status of camera and to configure the functions interactively. A Password can be configured in OSD menu and OSD menu can be protected.
- The information such as Camera ID, Pan/Tilt Angle, Time/Date, Alarm Input and Preset information is displayed on screen.

#### ❑ **Alarm In/Out Function**

- 3 alarm sensor inputs and 1 alarm sensor outputs are available.
- Alarm sensor input is decoupled with photo-couplers to avoid external electric noise and shock perfectly.
- Both of N.O.(Normal Open) sensors and N.C.(Normal Close) sensors can be used and the signal range of the sensor input is from DC 5.0V to 12.0V for various applications.
- The camera can be set to move to a Preset position or to run functions such as Pattern, Swing and Group when there are external sensor activations. Also “Post Alarm” function is possible, which is supposed to activate after user-defined time period and sequentially in succession to the action by external sensor activations.

#### ❑ **Reserved Presets(Hot Keys)**

- Most camera setup options can be set up easily and directly with the reserved presets (Hot Keys), without entering into OSD menu. For more information, refer to “Reserved Presets(Hot Keys)” in this manual.

#### ❑ **Dual Power Input**

- The input power source is DC 12 V or AC 24 V.

#### ❑ **Perfect Outdoor Environment Compatibility and Easy Installation**

- The fans and heaters are built-in in the camera for cold and hot temperature environment. Also idealistic mechanical design protects the camera from water and dust. (IP67 when installed properly with wall mount bracket only / Only for outdoor models)
- It is easy to install and repair the camera.

## Package Component

### □ Product & Accessories

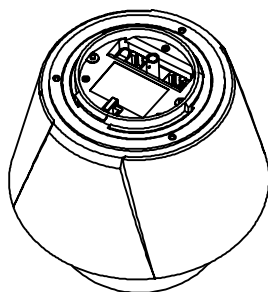

● Main Body & Dome Cover (Wall/Ceiling model)

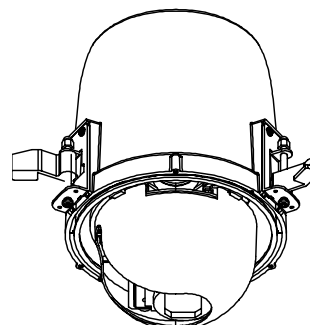
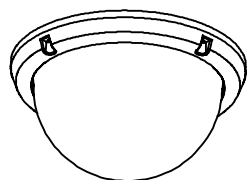

● Main Body & Dome Cover (In-ceiling model)

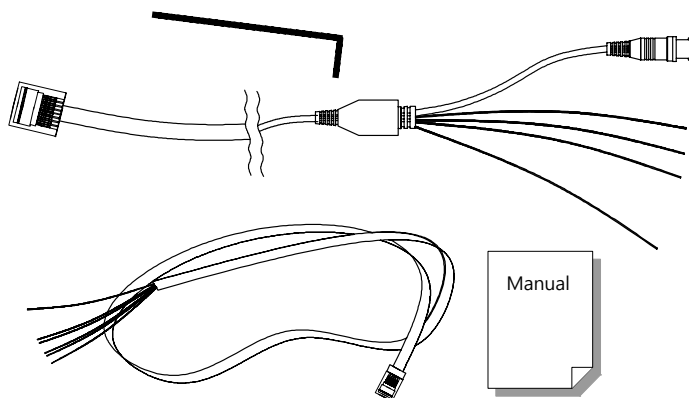

● Default Accessories  
[Main Cable, I/O Cable, Wrench, Owner's Manual]

□ Brackets (Optional)

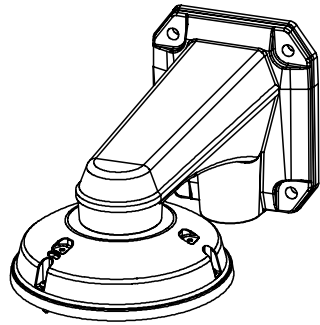

● Wall Mount Bracket  
[Screws :TORX Machine M4×L18, Hex Lag  
#14×50]

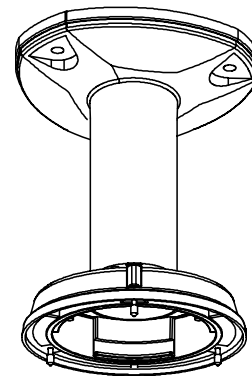

● Ceiling Mount Bracket  
[Screws :TORX Machine M4×L18, Anchor Bolt  
3/8"×70]

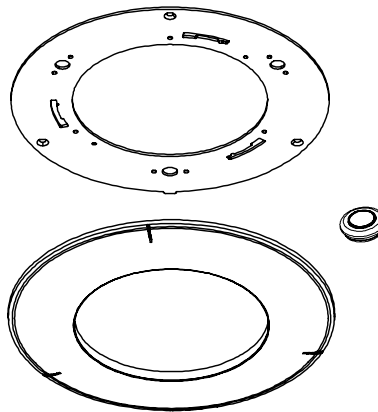

● In-Ceiling Mount Bracket  
[Screws :Tapping FH Ø4×L20, Machine Sams M3×L8]

## Main Part Description

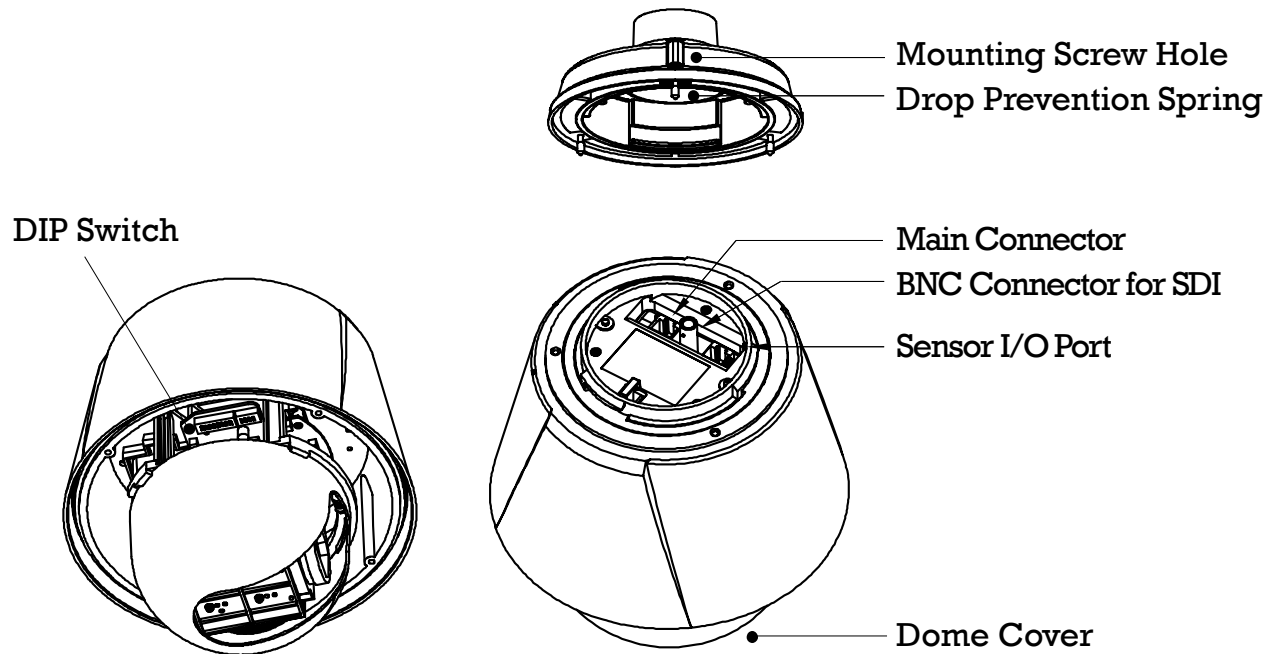

- **Dome Cover** Do not detach the protection vinyl from the dome cover before finishing all the installation process to protect the dome cover from scratches or dust.
- **DIP Switch** Used to set up camera IDs and protocols.
- **Drop Prevention Spring** This part keeps the camera from dropping during installation and maintenance. After install the Bracket, please, hang the spring to the drop prevention hook of main body as shown in picture for further tasks.
- **Mounting Screw Hole** Used to assemble the main body with a bracket with screws.
- **Main Connector** Used for the power wire, the composite video signal and the RS-485 communication cable connection.
- **BNC Connector for SDI** Used for the HD-SDI video signal connection.
- **Sensor I/O Port** Used for the sensor in/out connection.

## DIP Switch Setup

Before installing the camera, set up the DIP switch to configure the camera ID and the communication protocol.

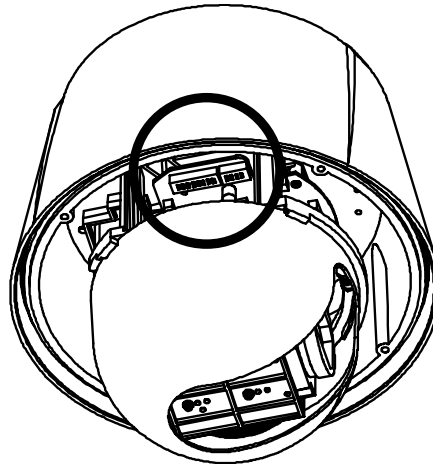

### □ Camera ID Setup



- ID numbers of cameras are set up with binary numbers. See the examples shown below.

Pin	1	2	3	4	5	6	7	8
Binary Value	1	2	4	8	16	32	64	128
ex) ID=5	on	off	on	off	off	off	off	off
ex) ID=10	off	on	off	on	off	off	off	off

- The camera ID range is “1~255”. **Camera ID must not be “0”!**
- The factory default of the camera ID is “1”.
- Match the camera ID with the Cam ID setting of your DVR or Controller to control the camera.
- If you are connecting a single camera to a controller, terminate the camera. When connecting more than one camera to a single controller, terminate the last camera on the communication line. The last camera means the camera farthest in cable length from the controller.
- Note that the total length of the communication cable between a controller and the camera(s) on the same communication line must be less than 1.2Km.

❑ Communication Protocol Setup

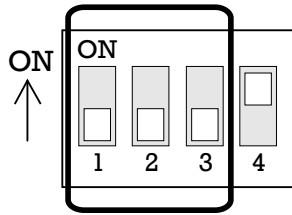

- Select an appropriate Protocol with the DIP switch combination.

Switch Mode			Protocol
P0 (Pin 1)	P1 (Pin 2)	P2 (Pin 3)	
OFF	OFF	OFF	PELCO-D, 2400 bps
ON	OFF	OFF	PELCO-D, 9600 bps
OFF	ON	OFF	PELCO-P, 4800 bps
ON	ON	OFF	PELCO-P, 9600 bps
Others			Reserved

- Match the camera protocol with the camera protocol in the setting of your DVR or controller to control the camera.
- Adjust the DIP switch after turning off the camera. If you changed the camera protocol by changing the DIP S/W, the change will be effective after you reboot the camera.
- The factory default protocol is “Pelco-D, 2400 bps”.

## Installation with Ceiling Mount Bracket

- ① Remove the ceiling tile from the ceiling and cut a hole whose diameter is 30~40mm on the ceiling tile to pass the wire(s) and cable(s) through to the upside of the ceiling. (In case of the wiring and cabling through the mounting surface only) Then prepare the ceiling mount bracket. Pull the wire(s) for the system as below. (Anchor Bolt 3/8"×70)
- ② Hook up "Drop Prevention Spring" on main body to prevent camera from unexpected drop and pull the wire(s) and cable(s) for the system as below.

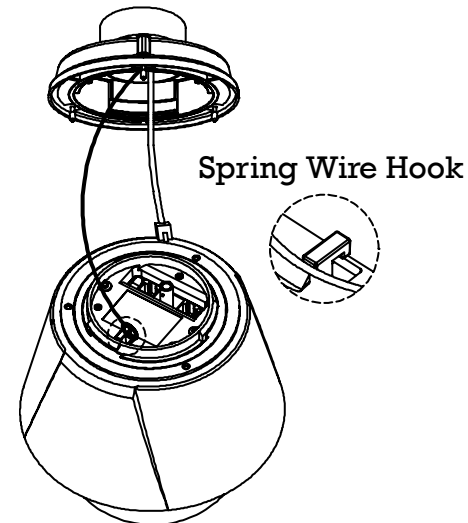
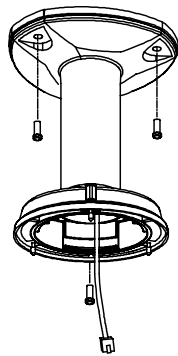

- ③ Line up the mold lines and assemble main body to mount adaptor and turn it. And assemble the main both with the camera mount adaptor with the 3 screws. (TORX SCREW M4×18).
- ④ Screw the dome cover to the main body and remove the protection vinyl from the dome cover.

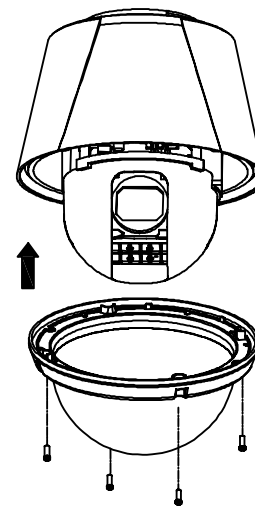
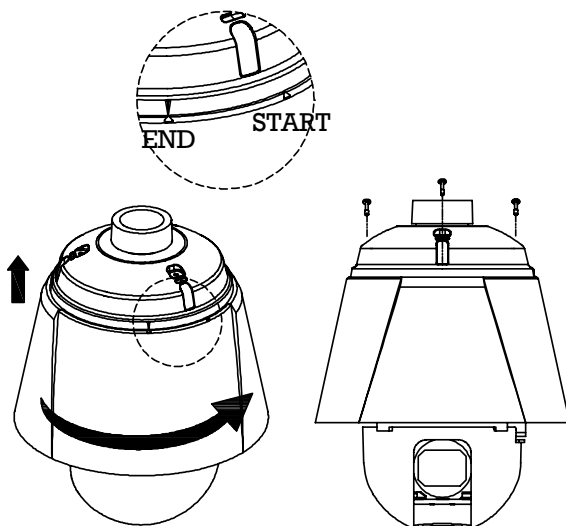

### **Important Notice**

- Before starting the installation, make sure that the Camera ID and Protocol are set up properly.
- To adjust the installation height from the mounting surface, the pipe and coupler should be needed between the surface mount part of the ceiling mount bracket and the camera mount part of the ceiling mount bracket. Note that they are not supplied by the manufacturer.

## Installation with Wall Mount Bracket

- ① Make a hole whose diameter is 30~40mm on the mounting surface to pass the wire(s) and cable(s) through the mounting surface. (In case of the wiring and cabling through the mounting surface only) Then prepare the wall mount bracket. Pull the wire(s) and cable(s) for the system as below. Attach the wall mount bracket to the mounting surface. (Hex Lag #14×50)
- ② Hook up “Drop Prevention Spring” on main body to prevent camera from unexpected drop and pull the wire(s) and cable(s) for the system as below.

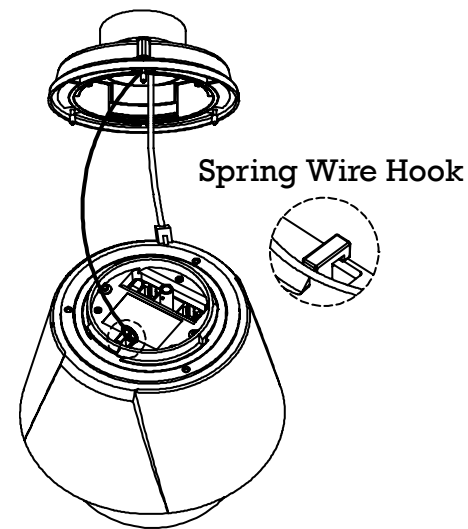
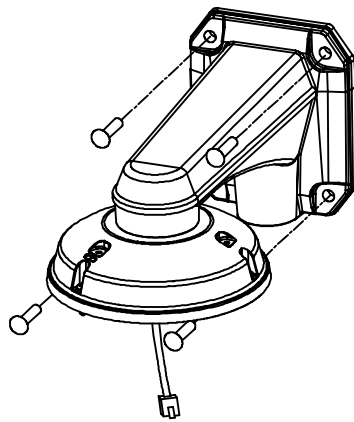

- ③ Line up the mold lines and assemble main body to mount adaptor and turn it. And assemble the main both with the camera mount adaptor with the 3 screws. (TORX SCREW M4×18).
- ④ Screw the dome cover to the main body and remove the protection vinyl from the dome cover.

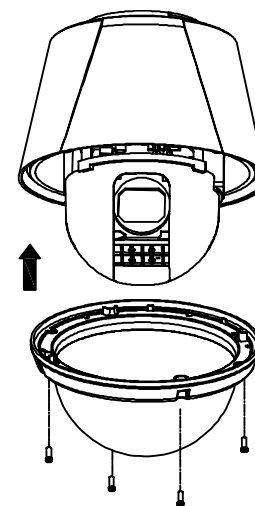
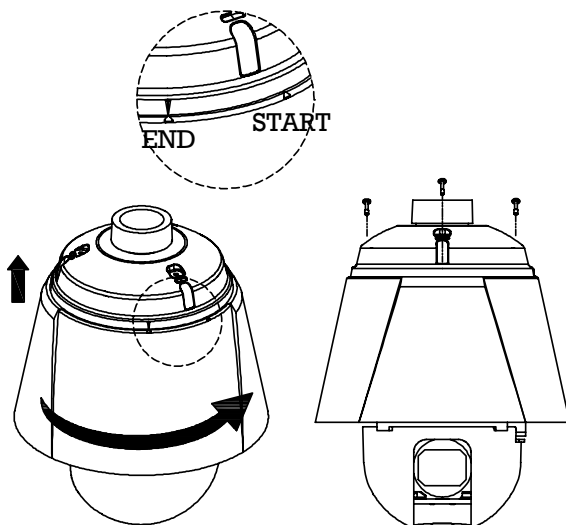

### **Important Notice**

- Before starting the installation, make sure that the Camera ID and Protocol are set up properly.



## Installation with In-ceiling Bracket

- ① Assemble the dome cover and the bracket with the main body

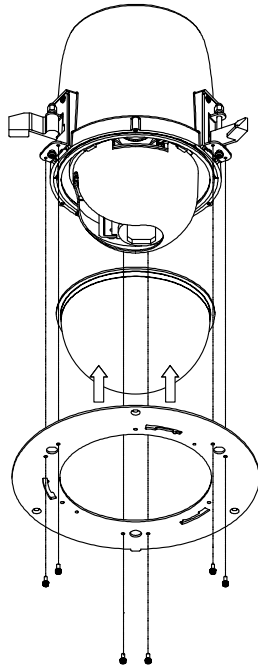

- ② Cut a hole whose diameter is 215mm on the ceiling tile and insert the camera into the hole. Open the cover and make all the connections.

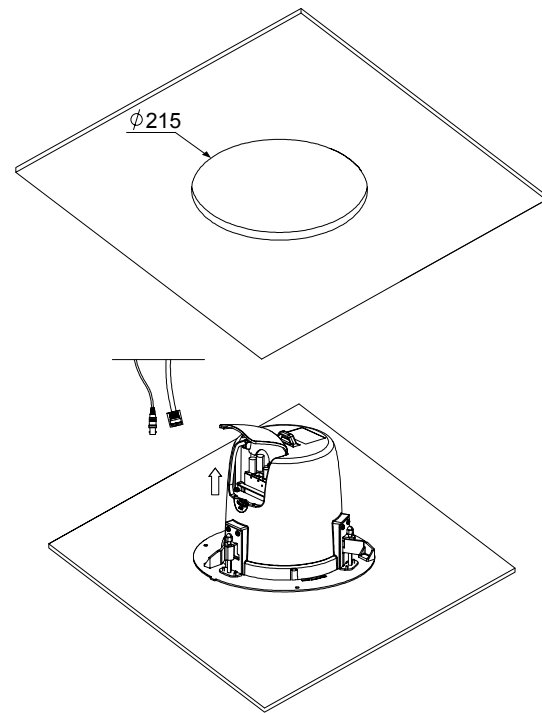

- ③ Install the ceiling tile to the ceiling. Fix the camera to the ceiling tile with the Guide Hook Screws.

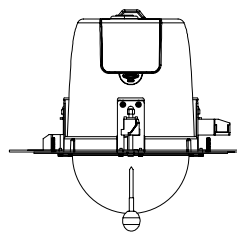
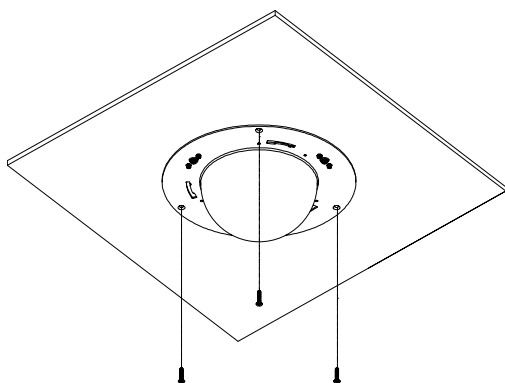

- ④ Assemble the Deco-Ring with the camera by spinning.

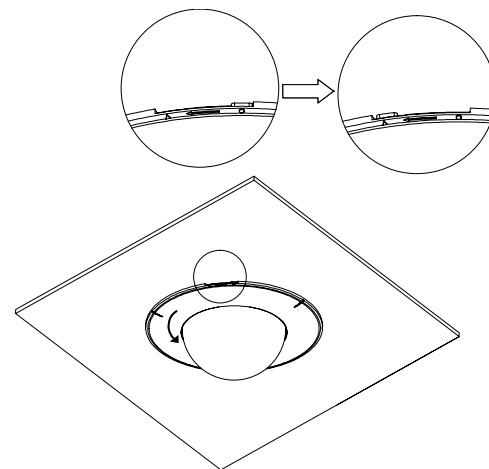

### **Important Notice**

- Before starting the installation, make sure that the Camera ID and Protocol are set up properly.

## Wiring and Cabling

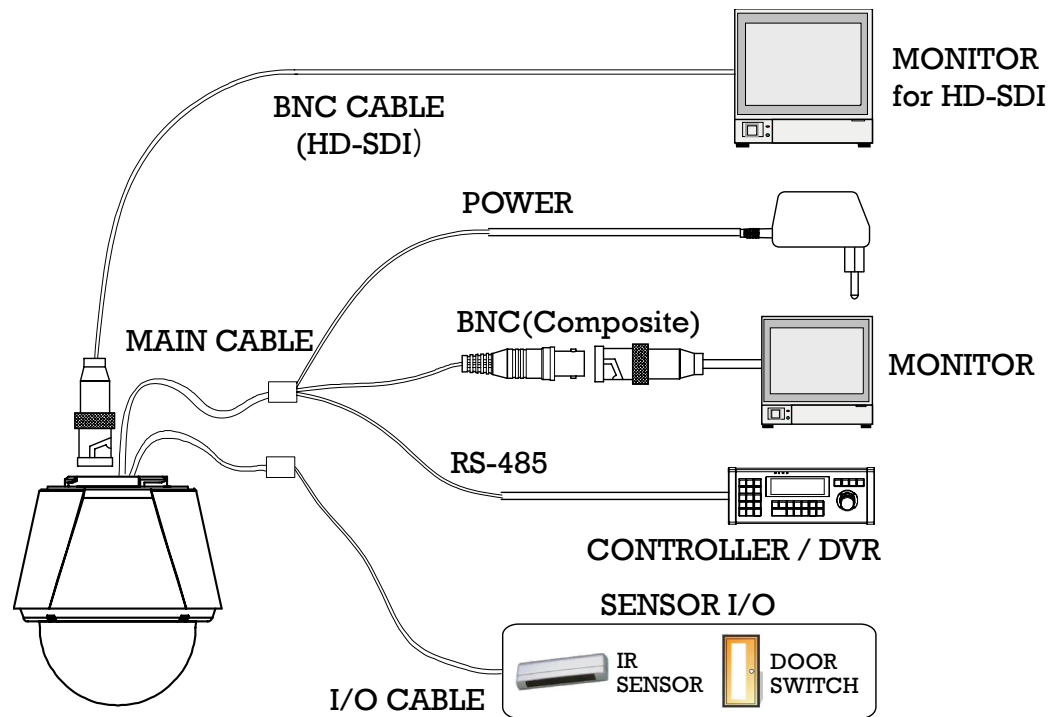

### Port Description

#### ● Main Cable

Port Pin Number (RJ45)	Connector / Wire Color	Signal
1	BNC Connector	Composite Video +
2,4		Composite Video -
5	Red	RS-485 +
3	Yellow	RS-485 -
7	Orange	Power +
6,8	White	Power -

#### ● I/O Cable

Port Pin Number (RJ25)	Wire Color	Signal
1	Blue	IN COM +
2	Yellow	IN 1 -
3	Green	IN 2 -
4	Red	IN 3 -
5	Black	OUT A
6	White	OUT B

### ❑ Power Description

- Carefully check the voltage and current capacity of the rated power.

Power Input	Input Voltage Range	Current Consumption
DC12V Input	DC 11V ~ 18V	1.8A
AC24V Input	AC 17V ~ 29V	2.0A

- For the DC input, be careful with the polarity of DC power. The system should be permanently damaged by wrong DC input.
- In case that the length of the DC power wire is very long, there may be voltage drop and the system may not work properly. Make the length of the power wire as short as possible.

### ❑ RS-485 Communication

- For PTZ control, connect the cable(s) to your keyboard or DVR. To connect multiple cameras to a single controller, RS-485 communication should be connected in parallel as shown below. If you are connecting a single camera to a controller, terminate the camera. When connecting more than one camera to a single controller, terminate the last camera on the communication line. The last camera means the camera farthest in cable length from the controller. Note that the total length of the communication cable between a controller and the camera(s) on the same communication line must be less than 1.2Km.

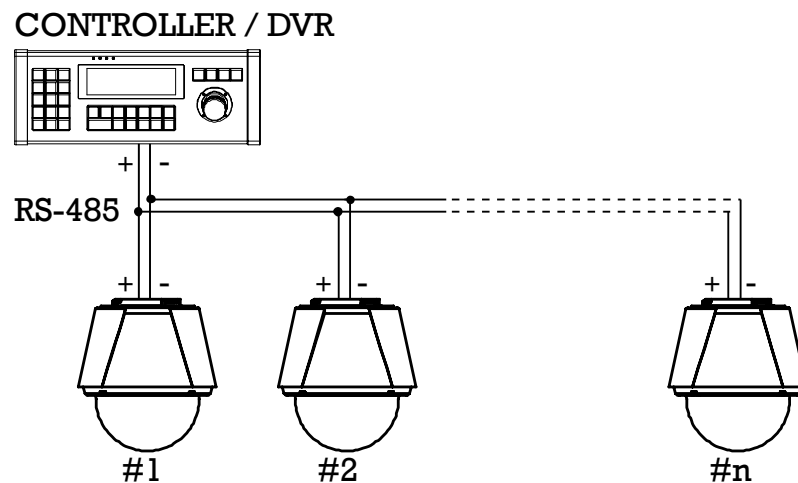

### ❑ HD-SDI Video Output

- Transmission Distance of HD-SDI Video Signal should be variable by cables. There may be no video on a monitor due to cable quality or specification. Use proper BNC Coaxial Cables after considering transmission distance.
- Your reference, see the below table. It shows transmission distances by cables.

Cable Type	Transmission Distance
RG11 14AWG	330 Meter
Belden 1694A 18AWG	230 Meter
RG6 18AWG (5C-HFBT)	210 Meter
RG59 20AWG	150 Meter
RG59 23AWG	110 Meter
3C2V 25AWG	90 Meter

□ Alarm Input

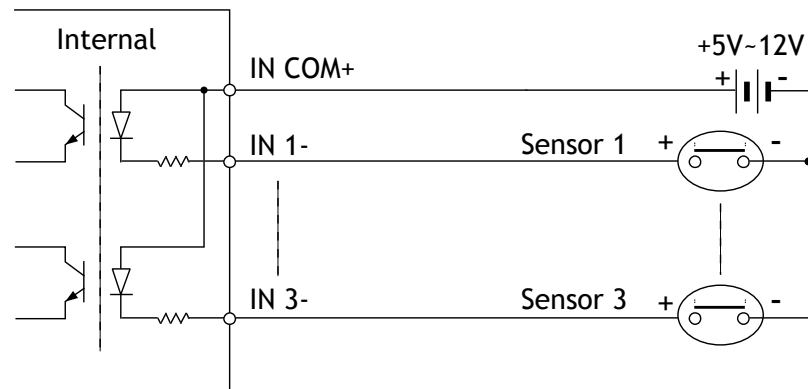

Before connecting sensors, check driving voltages and output signal types of the sensors. Since output signal types of the sensors are divided into Open Collector type and Voltage Output type in general, the wiring must be done properly after considering those types.

Signal	Description
IN COM+	The electric power source to drive input circuit. Connect the (+) wire of electric power source to drive the Sensors to this port as shown in the above circuit.
IN1 -,IN2 -,IN3 -	Connect the outputs of sensors to each port as shown in the above circuit.

If you want to use Alarm Input, the types of sensors must be selected in OSD menu. The sensor types are divided into Normal Open and Normal Close. If wrong sensor types are selected, alarms should be activated reversely to sensor inputs.

⊙ Normal Open	Output Voltage is high state when sensor is activated
⊙ Normal Close	Output Voltage is high state when sensor is not activated

□ Relay Output

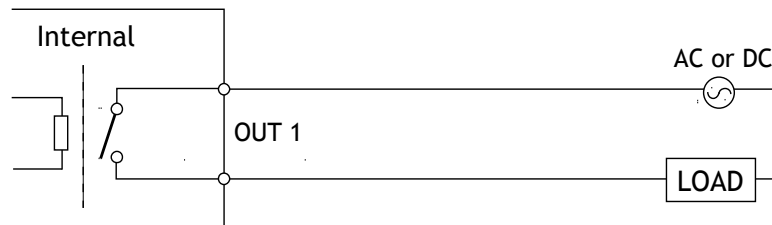

The maximum loads are as follows.

Power Type	DC Power	AC Power
Maximum Load	MAX. DC 24V, 1A	MAX. AC 125V, 0.5A

## Check Points before Operation

- Before turning on the system, check if the wire(s) and cable(s) are connected properly.
- Check if the camera ID on the controller is properly selected. The camera ID must be identical to that of the target camera. The camera ID can be checked by reading the DIP switch of the camera or on OSD.
- If your controller supports multi-protocols, the protocol must be changed to match to that of the camera.
- Adjust the DIP switch after turning off the camera. If you changed the camera protocol by changing the DIP S/W, the change will be effective after you reboot the camera.
- Since the operation method can be different by controllers, refer to your controller manual if the camera can not be controlled properly. The operation of this manual is based on the standard Pelco® Controller.

## Check Points for Preset and Pattern Function before Operation

- Check fully how to operate preset function and pattern function with your controller or DVR in advance to operate the camera functions when using a controller or a DVR.
- Refer to the following table when using standard Pelco® protocol controllers.

< Go Preset >	Input [Preset Number] and press [Preset] button shortly.
< Set Preset >	Input [Preset Number] and keep pressing [Preset] button for more than 2 seconds.
< Run Pattern >	Input [Pattern Number] and press [Pattern] button shortly.
< Set Pattern >	Input [Pattern Number] and keep pressing [Pattern] button for more than 2 seconds.

- If your controller or DVR has no pattern button or function, use the Hot Keys with preset numbers. For more information, refer to “**Reserved Presets(Hot Keys)**” in this manual.

## OSD Menu

- **Function** With OSD menu, the system can be properly configured for each application.
- **Entering into OSD** Go Preset [95]

## Reserved Presets (Hot Keys)

- **Description** Some Preset numbers are reserved to change some parameters without entering into OSD menu.
- **Hot Keys**

Go Preset [95]	:Entering into OSD menu
Go Preset [131~138]	:Running Pattern Function 1 ~ 8
Go Preset [141~150]	:Running Swing Function 1 ~ 10
Go Preset [151~158]	:Running Group Function 1 ~ 8
Go Preset [161]	:Turning off Relay Output
Set Preset [161]	:Turning on Relay Output
Go Preset [167]	:Setting Zoom Proportional Function to ON
Set Preset [167]	:Setting Zoom Proportional Function to OFF
Go Preset [170]	:Setting Camera BLC Mode to OFF
Go Preset [171]	:Setting Camera BLC Mode to ON
Go Preset [174]	:Setting Camera Focus Mode to AUTO
Go Preset [175]	:Setting Camera Focus Mode to Manual
Go Preset [176]	:Setting Camera Focus Mode to SEMI-AUTO
Go Preset [177]	:Setting Day & Night Mode to AUTO
Go Preset [178]	:Setting Day & Night Mode to NIGHT
Go Preset [179]	:Setting Day & Night Mode to DAY
Go Preset [190]	:Setting OSD Display Mode to AUTO (Except Privacy Mask)
Go Preset [191]	:Setting OSD Display Mode to OFF (Except Privacy Mask)
Go Preset [192]	:Setting OSD Display Mode to ON (Except Privacy Mask)
Go Preset [193]	:Setting all Privacy Mask Display to OFF
Go Preset [194]	:Setting all Privacy Mask Display to ON

## Preset

- **Function**                   MAX. 209 presets can be configured except the Reserved Presets (Hot Keys). Camera parameters such as White Balance, Auto Exposure and others can be set up independently and each preset can have its own parameter values independently from the other persets. When setting up presets with a controller, Label should be blank and Video settings should be set to "GLOBAL" as the default. To change the parameters, enter into OSD menu.
- **Setting Presets**       Set Preset [1~255]
- **Running Presets**      Go Preset [1~255]
- **Deleting Presets**     To delete Presets, enter into OSD menu.

## Swing

- **Function**               This function is that the camera moves repetitively between two preset positions at programmed speeds. When a swing function runs, the camera moves from the preset assigned as the 1st point to the preset assigned as the 2nd point in CW(Clockwise) direction. Then the camera moves from the preset assigned as the 2nd point to the preset assigned as the 1st point in CCW(Counterclockwise) direction.

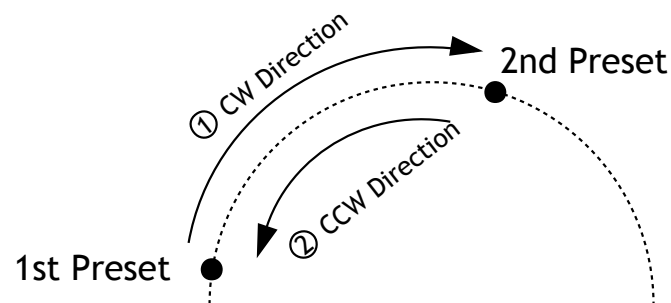

In case that the preset assigned as the 1st point and the preset assigned as the 2nd point are same, the camera turns on its axis by 360° in CW(Clockwise) direction and then it turns back on its axis by 360° in CCW(Counterclockwise) direction. The Swing speed is defined from 10°/sec to 180°/sec.

- **Setting Swings**       To set Swing, enter into OSD menu.
- **Running Swings**     Method 1) <Run Pattern> [Swing NO. + 10]     ex) Run Swing 3 : <Run Pattern> [13]  
Method 2) <Go Preset> [Swing NO. + 140]     ex) Run Swing 3 : <Go Preset> [143]
- **Deleting Swings**     To delete Swings, enter into OSD menu.



## Pattern

- **Function** This function is that the camera memorizes the path (mostly curve path) by the joystick of the controller and revives the trajectory operated by joystick as closely as possible.  
MAX. 4 Patterns are programmable and Maximum 768 communication commands can be programmed in a pattern.

- **Setting Patterns** A Pattern can be created by the following methods.

Method 1) <Set Pattern> [Pattern NO.]

- The Pattern programming window appears on the monitor as below.

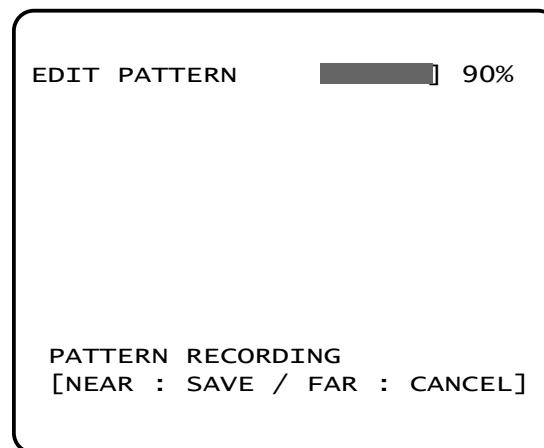

- The movement by Joystick can be memorized in a pattern.
- To save the recording, press **NEAR** key and to cancel, press **FAR** key.

Method 2) Programming in OSD Menu :See the section "How to use OSD Menu".

- **Running Patterns** Method 1) <Run Pattern> [Pattern NO.]      ex) Run Pattern 2 : <Run Pattern> [2]  
Method 2) <Go Preset> [Pattern NO. + 130]      ex) Run Pattern 2 : <Go Preset> [132]
- **Deleting Patterns** To delete Patterns, enter into OSD menu.

Note) When the system memorizes Patterns, the commands are stored in the memories, not the positions of Pan/Tilt/Zoom. Hence there might be small differences between the original path and the revived path by path type of Patterns. Note that it is not a problem in position precision.

## Group

- Function

This function is that the camera memorizes the combination of Presets, Pattern and/or Swings sequently and runs Presets, Pattern and/or Swings repetitively. MAX. 8 sets of Group are programmable. Each group can have MAX. 40 actions which are the combination of Preset, Pattern and Swing. Preset speed can be set up and the repeat number of Pattern & Swing can be set up in Group setup. Dwell time between actions can be set up also.

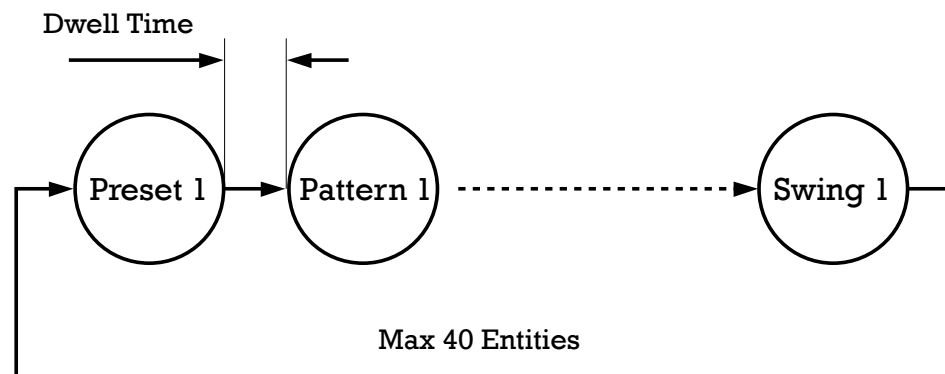

- Setting Groups To set Groups, enter into OSD menu.
- Running Groups Method 1) <Run Pattern> [Group NO. + 20] ex) Run Group 7 : <Run Pattern> [27]  
Method 2) <Go Preset> [Group NO. + 150] ex) Run Group 7 : <Go Preset> [157]
- Deleting Groups To delete Groups, enter into OSD menu.

## Other Functions

- Power Up Action This setting defines a specific activity (Preset, Pattern, Swing and Group) to be performed in the event that the power to the camera is cycled. This function enables the user to resume, after turning on power, the last action being executed before turning off the power. Most of actions such as Preset, Pattern, Swing and Group are available for this function but Jog actions are not available to resume.
- Auto Flip In case that tilt angle arrives at the top of tilt orbit(90°), zoom module camera turns on its axis by 180° at the top of tilt orbit and moves to opposite tilt direction (180°) to keep tracing targets.
- Parking Action This feature allows the camera to begin a specified operation after a programmed time of inactivity. This function makes the camera automatically run a pre-defined action if there is no command from controller for a pre-defined time period. "Wait Time" means how long a camera should wait for from the previous-last (most recent) command before running the pre-defined action. It can be set to 1 second ~ 3 hours.

- Alarm Input  
3 Alarm Inputs are available. When external sensors activate, the camera runs pre-defined actions such as Preset, Pattern, Swing and Group. After the pre-defined time period passed, "Post Alarm" activates, which is pre-defined. Note that only the latest alarm input is effective when multiple sensors are activated at the same time.
- Schedule  
8 Schedule are programmable. A camera runs functions such as Preset, Pattern, Swing and Group at assigned times. After a pre-defined time passes, "Post Action" runs. Also this function can be run periodically by pre-defined schedules. A Period can be configured by Once/Hourly/Daily/Weekly/Monthly.
- Privacy Zone Mask  
Privacy Zone Mask allows a user to program 8 rectangulars that can not be viewed by the operator of the system. To protect others' privacy, MAX. 8 Privacy Masks can be created on the arbitrary position to hide objects such as windows, shops or private house. With the Spherical Coordinates system, powerful Privacy Zone Mask function is possible. A mask area will move with pan and tilt functions and automatically adjust in size as the lens zooms telephoto and wide.
- Password for OSD  
A Password can be configured in OSD menu and OSD menu can be protected.  
**[Important Notice] It is mandatorily recommended that a user must take a memo for a password before a user applies a password to a system. When a Password is forgotten, a unit can not be unlocked and the unit is supposed to be shipped back to the manufacturer.**
- GLOBAL/LOCAL Image Setup  
WB(White Balance) and AE(Auto Exposure) can be set up independently for each preset. There are 2 modes, "Global" mode & "Local" mode. The Global mode is that WB and AE are set up totally and simultaneously for all presets. The Global parameter setup can be done in "VIDEO" menu. The Local mode is that WB and AE are set up independently for each preset. Each Local parameter such as WB and AE activates correspondingly when the camera arrives at each preset position. During jog operation, Global WB/AE value should be applied. All Local WB/AE values do not change although Global WB/AE value changes. The Local mode has the prior to the Global mode.
- Semi-Auto Focus  
This mode automatically exchanges focus modes between Manual Focus mode and Auto Focus mode by operation. Manual Focus mode activates in preset operation and Auto Focus mode activates during jog operation. With Manual mode at presets, Focus data is memorized in each preset in advance and the camera calls focus data in correspondence with presets as soon as the camera arrives at presets. It should shorten time to get focuses. The focus mode automatically changes to Auto Focus mode when jog operation starts.

## OSD Display

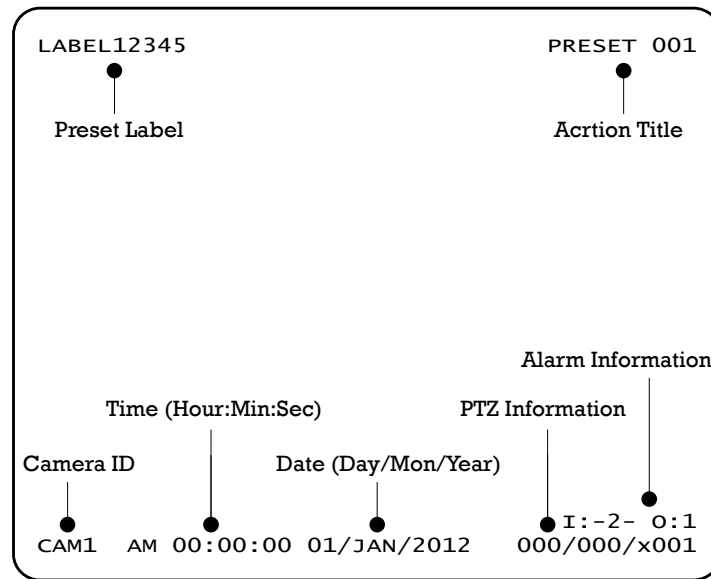

- P/T/Z Information Displays the pan/tilt positions and zoom magnification.
- Camera ID Displays the selected Camera ID (Address).
- Action Title Identifies Actions
  - "PRESET xxx" When Preset xxx is memorized or the camera reaches Preset xxx.
  - "PATTERN x" When Pattern x is in action.
  - "SWGx-PRESET xxx" When Swing x is in action. Displays both of Swing number and Preset number.
  - "UNDEFINED" When a undefined function is called to run
- Preset Label Displays preset labels when the camera arrives at presets.
- Alarm Information Displays activated alarms. This information shows current state of Alarm Inputs and Relay Outputs. If an Input point is **ON** state, it will show a number corresponding to each point. If an Input point is **OFF** state, '-' will be displayed.  
Example) The point 2 & 3 of inputs are **ON** and Output is **ON**.
 

I:-23 0:1
- Time/Date Displays the current time and date.
- Heater Status Displays the Heater Status. If the Heater is OFF, the background of OSD is Blue color. If the Heater is ON, the background of OSD is Orange color.

## Quick Programming Guide

- To move the cursor in the menu, use the joystick to the “**Up/Down**” direction or “**Left/Right**” direction.
- To change a value of an item, use “**Tele/Wide**” of the joystick in the controller.
- The menu items with “>>” always have sub-menus. To move to submenu, use “**Right**” of the joystick.
- To go to the previous-upper level menus, use “**Left**” of the joystick
- On the item with “>”, use “**Tele**” of the joystick to execute.

## Video Setup (30S, 20S model)

VIDEO	FOCUS MODE	SEMIAUTO
PTZ	WHITE BALANCE	AUTO
ACTION	- RED OFFSET	128
OSD	- BLUE OFFSET	128
SYSTEM	EXPOSURE MODE	AUTO
INFORMATION	- SHUTTER	1/60
	- IRIS	F5.6
	- GAIN	0 dB
	- BRIGHTNESS	10
	BLC	OFF
	WDR	OFF
	AUTO DSS	ON
	APERTURE	12
	DAY&NIGHT	AUTO
	DIGITAL ZOOM	ON
	IMAGE FLIP	OFF
	STABILIZATION	OFF
	PRIVACY MASK	>>
	HD-SDI RESOLUTION	1080p30

- Focus Mode [AUTO/MANUAL/SEMIAUTO]

Sets camera Focus mode.

### ○ SEMIAUTO Mode

This mode automatically exchanges focus modes between Manual Focus mode and Auto Focus mode by operation. Manual Focus mode activates in preset operation and Auto Focus mode activates during jog operation

With Manual mode at presets, Focus data is memorized in each preset in advance and the camera calls focus data in correspondence with presets as soon as camera arrives at presets. It should shorten time to get focuses. Focus mode automatically changes to Auto Focus mode when jog operation starts.

- **White Balance** [AUTO/MANUAL]  
Retains color balance over a color temperature range. In auto mode, this feature automatically processes the viewed image. In Manual mode, Red and Blue level can be set up manually.
- **Red Offset** [0 ~ 255]  
Adjusts the picture output in the red range.
- **Blue Offset** [0 ~ 255]  
Adjusts the picture output in the blue range.
- **Exposure Mode** [AUTO/MANUAL/SHUTTER/IRIS/BRIGHTNESS]  
Set Auto Exposure mode.
- **Shutter** [1/1 ~ 1/10000]  
If AE mode is set to SHUTTER mode or MANUAL mode, this can be set up. For Flickerless function, set the shutter mode to 1/100 in NTSC, 1/20 in PAL.
- **Iris** [CLOSE/F1.6~F14]  
If AE mode is set to IRIS mode or MANUAL mode, this can be set up.
- **Gain** [-3dB ~ 28dB]  
If AE mode is set to MANUAL mode, this can be set up.
- **Brightness** [0 ~ 31]  
If AE mode is set to BRIGHTNESS mode, this can be set up.
- **BLC** [ON/OFF]  
Sets Backlight Compensation. If a bright backlight is present, the subjects in the picture may appear dark or as a silhouette. Backlight compensation enhances objects in the center of the picture. The camera uses the center of the picture to adjust the iris. If there is a bright light source outside of this area, it will wash out to white. The camera will adjust the iris so that the object in the sensitive area is properly exposed.
- **WDR** [OFF/ON]  
The WDR(Wide Dynamic Range) is a function for dividing an image into several blocks and correcting blocked-up shadows and blown-out highlights in accordance with the intensity difference. It enables you to obtain images in which portions ranging from dark to light can be recognized, even when capturing a subject with a large intensity difference that is backlit or includes extremely light portions.

- **Auto DSS** [ON/OFF]  
When set to ON, ensure that the slow shutter is set to automatically when the brightness drops. Effective only when the AE mode is set to AUTO.  
The Auto DSS function is not available in WDR mode.
- **Aperture** [0 ~ 15]  
Adjust the enhancement of the edges of objects in the picture.
- **Day/Night** [AUTO/DAY/NIGHT]  
Sets Day&Night mode.
- **Digital Zoom** [ON/OFF]  
Sets the digital zoom functions to ON/OFF. If this is set to OFF, the optical zoom function runs but the zoom function stops at the end of optical zoom magnification.
- **Image Flip** [ON/OFF]  
Sets System Image Flip Function to ON/OFF. When this function is set to ON, flipped images always come out. When the camera is installed as Desktop type, set to ON to get proper images.
- **Stabilization** [ON/OFF]  
Compensates image vibrations by wind or others. The images with vibrations are compensated by Digital Zoom function and the image resolution with this function should be lower than normal image resolution when this function is turned on. This function is not supported on 20S model.
- **HD-SDI Resolution** NTSC : [1080p30/1080i60/720p60/720p30]  
PAL : [1080p25/1080i50/720p60/720p30]  
Sets the video resolution of HD-SDI. Match the resolution with the setting of monitor or DVR.  
If there is no confirmation within 10 seconds by pressing the **NEAR** button, it is automatically restored to its previous configuration.

**Video Setup (30T, 20T, 19T model)**

<b>VIDEO</b>	FOCUS MODE	SEMIAUTO
PTZ	WHITE BALANCE	AUTO
ACTION	- RED OFFSET	105
OSD	- BLUE OFFSET	112
SYSTEM	SHUTTER MODE	ESC
INFORMATION	- SHUTTER	1/60
	IRIS MODE	AUTO
	- IRIS	F1.6
	GAIN MODE	MEDIUM
	- GAIN	0 dB
	BRIGHTNESS	50
	BACKLIGHT	OFF
	- LEVEL	LOW
	- COLOR	1
	SENS-UP	AUTO
	- SENS-UP LIMIT	X2
	SSNR	MEDIUM
	SHARPNESS	12
	DAY&NIGHT	AUTO
	[NEXT : MORE]	

<b>VIDEO</b>	DIGITAL ZOOM	ON
PTZ	IMAGE FLIP	OFF
ACTION	STABILIZATION	OFF
OSD	PRIVACY MASK	>>
SYSTEM	HD-SDI RESOLUTION	1080p30
INFORMATION		



- **Focus Mode** [AUTO/MANUAL/SEMIAUTO/PUSHAUTO]  
Sets camera Focus mode.
  - SEMIAUTO Mode  
This mode automatically exchanges focus modes between Manual Focus mode and Auto Focus mode by operation. Manual Focus mode activates in preset operation and Auto Focus mode activates during jog operation.
  - PUSHAUTO Mode  
This mode automatically exchanges focus modes between Push Auto Focus mode and Auto Focus mode by operation. Push Auto Focus mode activates in preset operation and Auto Focus mode activates during jog operation. Only T20 model supports this mode.
  
- **White Balance** [ATW/MANUAL/AWC/ATW OUTDOOR/ATW INDOOR]  
Retains color balance over a color temperature range. In auto mode, this feature automatically processes the viewed image. In Manual mode, Red and Blue level can be set up manually.  
Only T20 model supports AWC, ATW Outdoor and ATW Indoor modes.
  
- **Red/Blue Offset** [0 ~ 255]  
Adjusts the picture output in the red/blue range.
  
- **Shutter** [ESC/A.Flicker/Manual(×60~1/33000sec or ×60~1/30000sec)]  
Sets Shutter Speed. Shutter Speed is the duration of the electronic shutter. If Iris is set to Manual and Shutter Speed is set to ESC, Shutter Speed has higher priority. If Shutter Speed is set to A.Flicker, to remove Flicker, Shutter Speed should be set to 1/100 sec. for NTSC and 1/120 for PAL
  
- **Iris** [AUTO/MANUAL(F1.6~F28/CLOSE or F1.35~F28/CLOSE)]  
Sets Iris to operate automatically or at a user-defined level. If Iris is set to Auto, Iris has higher priority in adjusting AE and Shutter Speed is fixed. Auto iris is the lens function that automatically opens closes the iris in response to changing light conditions.  
If Iris is set to Manual, Iris is fixed and Iris has lower priority in adjusting AE, in comparison with others.
  
- **Gain** [OFF/LOW/MIDDLE/HIGH/MANUAL(0~36dB or 0~42dB)]  
Sets AGC. This setting enhances image brightness automatically in case that luminance level of image signal is too low.
  
- **Brightness** [1~100]  
Adjusts the brightness of the images. Iris, The Shutter Speed and Gain are adjusted automatically in correspondence with each numeric value.

- **Backlight** [OFF/BLC/HLC]  
Sets Backlight Compensation. If a bright backlight is present, the subjects in the picture may appear dark or as a silhouette. Backlight compensation enhances objects in the center of the picture. The camera uses the center of the picture to adjust the iris. If there is a bright light source outside of this area, it will wash out to white. The camera will adjust the iris so that the object in the sensitive area is properly exposed.  
HLC(High Light Compensation) function removes the high light in a limited environment such as parking garage. The level is adjustable in the BLC mode and the level and masking color are adjustable in the HLC mode.  
The WDR(Wide Dynamic Range) is a function for dividing an image into several blocks and correcting blocked-up shadows and blown-out highlights in accordance with the intensity difference. It enables you to obtain images in which portions ranging from dark to light can be recognized, even when capturing a subject with a large intensity difference that is backlit or includes extremely light portions. The WDR function is supported on 30T model only.
- **Sens-Up** [AUTO(×2~×60)/OFF]  
Sets SENS-UP. This setting activates Slow Shutter function when luminance of image (signal) is too dark.  
It is possible to set up the maximum number of frames piled up one on another by Slow Shutter function
- **SSNR** [OFF/LOW/MIDDLE/HIGH]  
Sets SSNR. This setting enhances the images by deducting noises when the gain level of the mages is too high.
- **Sharpness** [1-31]  
Sets image sharpness to enhance pictures.
- **Day/Night** [AUTO/DAY/NIGHT]  
Sets Day&Night mode.
- **Digital Zoom** [ON/OFF]  
Sets the digital zoom functions to ON/OFF. If this is set to OFF, the optical zoom function runs but the zoom function stops at the end of optical zoom magnification.
- **Image Flip** [ON/OFF]  
Sets System Image Flip Function to ON/OFF. When this function is set to ON, flipped images always come out. When the camera is installed as Desktop type, set to ON to get proper images.

- Stabilization [ON/OFF]

Compensates image vibrations by wind or others. The images with vibrations are compensated by Digital Zoom function and the image resolution with this function should be lower than normal image resolution when this function is turned on. Also this function may not work properly in the following cases.

  - Dark scene or Low contrast scene
  - High frequency vibration
  - During Pan/Tilt/Zoom/Focus moving
  - During Iris/Shutter/Gain moving
  
- HD-SDI Resolution
  - NTSC : [1080p30/1080i60/720p60/720p30]
  - PAL : [1080p25/1080i50/720p60/720p30]

Sets the video resolution of HD-SDI. Match the resolution with the setting of monitor or DVR.

If there is no confirmation within 10 seconds by pressing the **NEAR** button, it is automatically restored to its previous configuration.

**Video Setup (20W model)**

<b>VIDEO</b>	FOCUS MODE	SEMIAUTO
PTZ	WHITE BALANCE	AUTO
ACTION	- RED OFFSET	10
OSD	- BLUE OFFSET	10
SYSTEM	EXPOSURE MODE	AUTO
INFORMATION	- SHUTTER	1/60
	- IRIS	13
	- GAIN	+19 dB
	- BRIGHTNESS	19
	BLC	OFF
	WDR	OFF
	DEFOG	OFF
	- LEVEL	5
	AUTO DSS	ON
	APERTURE	8
	DAY&NIGHT	AUTO
	DIGITAL ZOOM	ON
	IMAGE FLIP	OFF
	[NEXT : MORE]	

<b>VIDEO</b>	PRIVACY MASK	>>
PTZ	HD-SDI RESOLUTION	1080p30
ACTION		
OSD		
SYSTEM		
INFORMATION		

- **Focus Mode** [AUTO/MANUAL/SEMIAUTO]  
Sets camera Focus mode.
  - **SEMIAUTO Mode**  
This mode automatically exchanges focus modes between Manual Focus mode and Auto Focus mode by operation. Manual Focus mode activates in preset operation and Auto Focus mode activates during jog operation.  
With Manual mode at presets, Focus data is memorized in each preset in advance and the camera calls focus data in correspondence with presets as soon as camera arrives at presets. It should shorten time to get focuses. Focus mode automatically changes to Auto Focus mode when jog operation starts.
- **White Balance** [AUTO/MANUAL]  
Retains color balance over a color temperature range. In auto mode, this feature automatically processes the viewed image. In Manual mode, Red and Blue level can be set up manually.
- **Red Offset** [0 ~ 20]  
Adjusts the picture output in the red range.
- **Blue Offset** [0 ~ 20]  
Adjusts the picture output in the blue range.
- **Exposure Mode** [AUTO/MANUAL/SHUTTER/IRIS/BRIGHTNESS]  
Set Auto Exposure mode.
- **Shutter** [1/7(6) ~ 1/60000]  
If AE mode is set to SHUTTER mode or MANUAL mode, this can be set up.
- **Iris** [CLOSE/1~13]  
If AE mode is set to IRIS mode or MANUAL mode, this can be set up.
- **Gain** [0dB ~ 45dB]  
If AE mode is set to MANUAL mode, this can be set up.
- **Brightness** [0 ~ 31]  
If AE mode is set to BRIGHTNESS mode, this can be set up.
- **BLC** [ON/OFF]  
Sets Backlight Compensation. If a bright backlight is present, the subjects in the picture may appear dark or as a silhouette. Backlight compensation enhances objects in the center of the picture. The camera uses the center of the picture to adjust the iris. If there is a bright light source outside of this area, it will wash out to white. The camera will adjust the iris so that the object in the sensitive area is properly exposed.

- WDR [OFF/ON]  
The WDR(Wide Dynamic Range) is a function for dividing an image into several blocks and correcting blocked-up shadows and blown-out highlights in accordance with the intensity difference. It enables you to obtain images in which portions ranging from dark to light can be recognized, even when capturing a subject with a large intensity difference that is backlit or includes extremely light portions.
- Defog [ON/OFF]  
Sets the Defog function. When set to ON, WDR function does not work.
- Auto DSS [ON/OFF]  
When set to ON, ensure that the slow shutter is set to automatically when the brightness drops. Effective only when the AE mode is set to AUTO.  
The Auto DSS function is not available in WDR mode.
- Aperture [0 ~ 10]  
Adjust the enhancement of the edges of objects in the picture.
- Day/Night [AUTO/DAY/NIGHT]  
Sets Day&Night mode.
- Digital Zoom [ON/OFF]  
Sets the digital zoom functions to ON/OFF. If this is set to OFF, the optical zoom function runs but the zoom function stops at the end of optical zoom magnification.
- Image Flip [ON/OFF]  
Sets System Image Flip Function to ON/OFF. When this function is set to ON, flipped images always come out. When the camera is installed as Desktop type, set to ON to get proper images.
- HD-SDI Resolution  
NTSC : [1080p30/1080i60/720p60/720p30]  
PAL : [1080p25/1080i50/720p60/720p30]  
Sets the video resolution of HD-SDI. Match the resolution with the setting of monitor or DVR.  
If there is no confirmation within 10 seconds by pressing the **NEAR** button, it is automatically restored to its previous configuration.

## Video Setup (28L, 30L model)

<b>VIDEO</b>	FOCUS MODE	SEMI-AUTO
PTZ	- FOCUS DIST	50cm
ACTION	WHITE BALANCE	AUTO
OSD	- MANUAL MODE	INDOOR
SYSTEM	- RED OFFSET	0
INFORMATION	- BLUE OFFSET	0
	IRIS	AUTO
	- LEVEL	200
	AGC	30
	BRIGHTNESS	50
	SHUTTER MODE	AUTO
	SENS-UP	OFF
	3DNR	MEDIUM
	WDR/BLC	OFF
	- LEVEL	LOW
	- ACE	OFF
	SHARPNESS	34
	[NEXT : MORE]	

<b>VIDEO</b>	COLOR	ON
PTZ	- COLOR LEVEL	0
ACTION	EIS	OFF
OSD	DAY&NIGHT	AUTO
SYSTEM	DIGITAL ZOOM	ON
INFORMATION	IMAGE FLIP	OFF
	PRIVACY MASK	>>
	HD-SDI RESOLUTION	1080p30

- Focus Mode [AUTO/MANUAL/SEMIAUTO]  
Sets camera Focus mode.
  - SEMIAUTO Mode  
This mode automatically exchanges focus modes between Manual Focus mode and Auto Focus mode by operation. Manual Focus mode activates in preset operation and Auto Focus mode activates during jog operation
- Focus Dist [50cm/1M/3M/5M]  
Sets the minimum focus distance.
- White Balance [AUTO/MANUAL/ATW]  
The color temperature range of Auto mode is 3500K~6500K, and 1700K~11000K in ATW mode. In Manual mode, Indoor/Outdoor mode and Red/Blue level can be set up manually. Indoor mode is based on 3600K and Outdoor mode is based on 6500K.
- Red/Blue Offset [-100 ~ 100]
- Iris [AUTO/MANUAL]  
Sets Iris mode. Iris level can be set up to 15(Close)~240(Open) in manual mode.
- AGC [0 ~ 30]  
This setting enhances image brightness automatically in case that luminance level of image signal is too low. If this is set to 0, the AGC function is off.
- Brightness [0 ~ 100]  
Adjusts the brightness of the images.
- Shutter Mode [OFF/ AUTO/A.Flicker/(×32 ~ 1/10000<sup>±</sup>)]  
The shutter is set automatically according to the brightness of subject in Auto mode. When it is set to OFF, the shutter speed is fixed to 1/30sec. If Shutter Speed is set to A.Flicker, to remove Flicker, Shutter Speed should be set to 1/100 sec. for NTSC and 1/120 for PAL.
- Sens-Up [(×2 ~ ×32)/OFF]  
This setting activates Slow Shutter function when luminance of image (signal) is too dark. It is possible to set up the maximum number of frames piled up one on another by Slow Shutter function.
- 3DNR [OFF/LOW/MEDIUM/HIGH]  
This setting enhances the images by deducting noises when the gain level of the mages is too high.



- **WDR/BLC** [OFF/WDR/BLC]  
Sets Backlight Compensation. If a bright backlight is present, the subjects in the picture may appear dark or as a silhouette. The camera uses the center of the picture to adjust the iris. If there is a bright light source outside of this area, it will wash out to white. The camera will adjust the iris so that the object in the sensitive area is properly exposed.  
The WDR(Wide Dynamic Range) is a function for dividing an image into several blocks and correcting blocked-up shadows and blown-out highlights in accordance with the intensity difference. It enables you to obtain images in which portions ranging from dark to light can be recognized, even when capturing a subject with a large intensity difference that is backlit or includes extremely light portions.  
In a case of extreme contrast between light and shade, ACE function even more brighten the dark portion of the image with the WDR function.
- **Sharpness** [0 ~ 68]  
Sets image sharpness to enhance pictures.
- **Color** [ON/OFF]  
Set the image to Color or B/W mode. The color level can be adjusted in color mode (-50 ~ 50)
- **EIS** [ON/OFF]  
Compensates image vibrations by wind or others. The images with vibrations are compensated by Digital Zoom function and the image resolution with this function should be lower than normal image resolution when this function is turned on.
- **Day/Night** [AUTO/DAY/NIGHT]  
Sets Day&Night mode.
- **Digital Zoom** [ON/OFF]  
Sets the digital zoom functions to ON/OFF. If this is set to OFF, the optical zoom function runs but the zoom function stops at the end of optical zoom magnification.
- **Image Flip** [ON/OFF]  
Sets System Image Flip Function to ON/OFF. When this function is set to ON, flipped images always come out. When the camera is installed as Desktop type, set to ON to get proper images.
- **HD-SDI** NTSC : [1080p30/1080i60/720p60/720p30]  
Resolution PAL : [1080p25/1080i50/720p60/720p30]  
Sets the video resolution of HD-SDI. Match the resolution with the setting of monitor or DVR.  
If there is no confirmation within 10 seconds by pressing the **NEAR** button, it is automatically restored to its previous configuration.

## Privacy Mask Setup

```

PRIVACY MASK

MASK NO           1 UNDEFINED
CLEAR MASK        >
DISPLAY MASK      OFF
EDIT MASK         >>
MASK COLOR        BLACK
  
```

Privacy Zone Mask allows the user to program 8 rectangulars that can not be viewed by the operator of the system. To protect privacy, MAX. 8 Privacy Masks can be created on the arbitrary position to hide objects such as windows, shops or private house. With the Spherical Coordinates system, powerful Privacy Zone Mask function is possible. A mask area will move with pan and tilt functions and automatically adjust in size as the lens zooms telephoto and wide.

- Mask NO [1~8]  
Selects a Mask number to program. If the selected mask has already data, the camera moves as it was programmed. Otherwise, "UNDEFINED" will be displayed.
- Clear Mask Deletes the mask data of the selected mask number.
- Display Mask [ON/OFF]  
Sets if the mask of the selected mask number shows or not on the screen.
- Mask Color [BLACK/GRAY1~6/WHITE/RED/GREEN] or [0 ~ 2]  
Sets the color of mask. The setting value is applied to all masks.  
**① 30S, 20S, 20W, 28L, 30L models only**

### □ Privacy Mask Area Setup

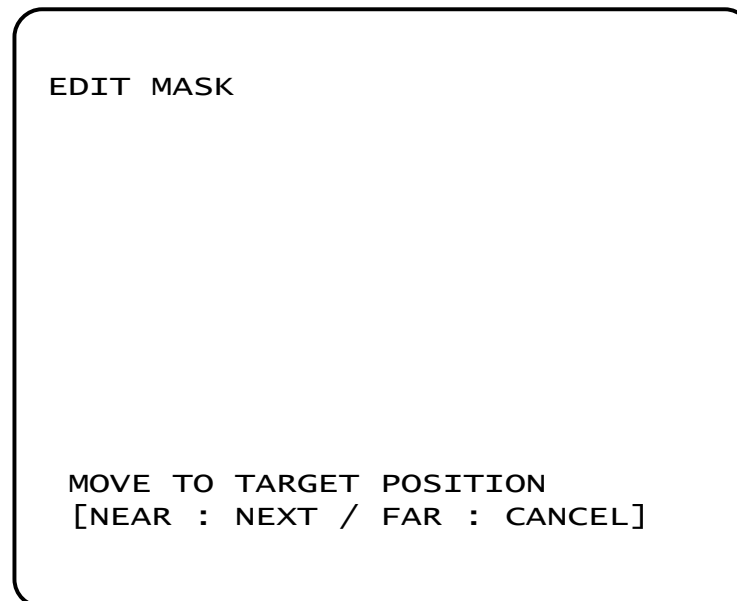

Move your camera to an area to mask, and press **NEAR** button. Then a mask will be displayed in the center of screen.

### □ Privacy Mask Size Setup

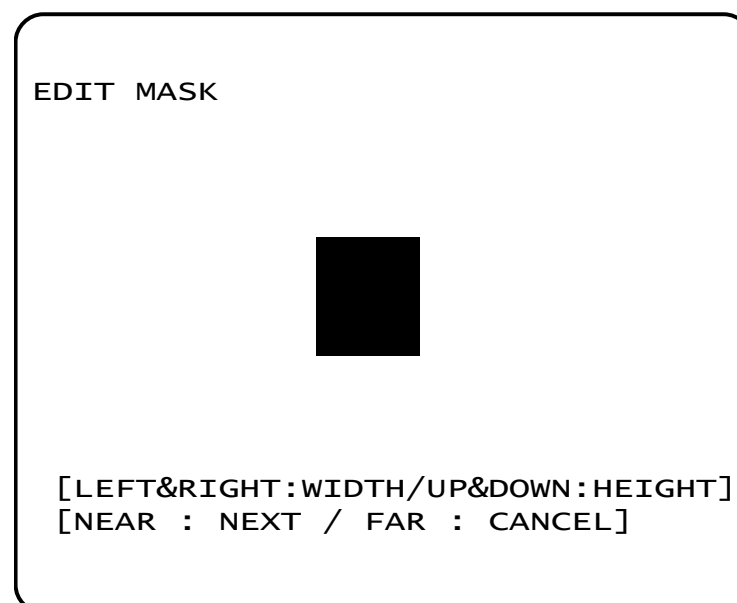

Adjust the mask size. Use the joystick or the arrow buttons of your controller to adjust mask size. (**Left/Right/Up/Down**)

## PTZ Setup

```

VIDEO
PTZ          POWER UP ACTION          ON
ACTION       AUTO PARKING             OFF
OSD          - ACTION TYPE            HOME
SYSTEM       - ACTION NUMBER         -
INFORMATION  - WAIT TIME              00:10:00
              AUTO FLIP               ON
              JOG MAX SPEED           120/SEC
              JOG DIRECTION           INVERSE
              ZOOM PROPORTIONAL JOG   ON
              FREEZE IN PRESET        OFF
  
```

- **Power Up Action** [ON/OFF]  
Refer to "Other Functions" section.
- **Auto Parking** [ON/OFF]  
If Auto Parking is set to ON, the camera runs an assigned function automatically if there is no PTZ command during the programmed "Wait Time".
- **Action Type / Action Number** [HOME/PRESET/SWING/PATTERN/GROUP/PREV ACTION]  
This feature defines the activity when the camera parks. If Park Action is set to "HOME", the camera moves to the home position which is memorized when the system boots. If Park Action is set to "PREV. ACTION", the camera runs the previous action which it ran most recently.
- **Wait Time** [1~59 sec. / 1~180 min.]  
Wait Time can be programmed from 1 second to 180 minutes.
- **Auto Flip** [ON/OFF]  
Refer to "Other Functions" section.
- **Jog Max Speed** [1°/sec ~360°/sec]  
Sets the maximum jog speed.

- Jog Direction [INVERSE/NORMAL]  
Sets the Jog Direction. If this is set to 'Inverse' , the view direction in the screen is same as the direction of joystick. If this is set to 'Normal' , the view direction in the screen is the reverse direction of joystick.
- Zoom [ON/OFF]  
Proportional Jog Decides whether jog operation speed is interlocked with zoom magnification. If this is set to "ON" , jog operation speed is interlocked with zoom magnification and jog operation speed becomes lower for easier control as zoom magnification becomes higher.
- Freeze in [ON/OFF]  
Preset Sets Frame Freeze Function. This feature freezes the scene on the monitor when going to a preset. At the start point of a preset movement, a camera starts freezing the image of the start point. Camera keeps displaying the image of the start point during preset movement and does not display the images which camera gets during preset movement. As soon as camera stops at preset end point, camera starts displaying live images which it gets at the end preset point. This feature also reduces bandwidth when working with digital systems or digital network systems.

## ACTION Setup

```
VIDEO
PTZ
ACTION MOTION EDIT LOCK OFF
OSD PRESET >>
SYSTEM SWING >>
INFORMATION PATTERN >>
GROUP >>
ALARM TRIGGER >>
SCHEDULE >>
```

- Motion Edit Lock

[ON/OFF]

If Motion Lock is set to ON, it is impossible to set up and delete Preset, Swing, Pattern and Group. It is possible only to run those functions. To set up and delete those functions, enter into OSD menu.

## PRESET Setup

PRESET	
PRESET NO	1 UNDEFINED
CLEAR PRESET	>
EDIT SCENE	>>
EDIT LABEL	>> [                      ]
RELAY OUT	OFF
CAMERA LOCAL SETTING	OFF
WHITE BALANCE	AUTO
- RED OFFSET	128
- BLUE OFFSET	128
EXPOSURE MODE	AUTO
- SHUTTER	1/60
- IRIS	F6.8
- GAIN	2 dB
- BRIGHTNESS	10
BLC	OFF
WDR	OFF
AUTO DSS	ON
APERTURE	12
DAY&NIGHT	AUTO

- Preset No [1~255] MAX. 209 Presets except the Reserved Presets (Hot Keys)  
Selects a preset number to set up. If a selected preset is already defined, the camera moves to the pre-defined position. If a selected preset is not defined, "UNDEFINED" shows on the monitor.
- Clear Preset Deletes the data of the selected Preset.
- Edit Scene Re-defines the scene position of the selected Preset.
- Edit Label Edits the label of the selected Preset to show on the monitor when the preset runs. MAX. 10 alphanumeric characteristics are allowed.
- Relay Out Defines the relay output.
- Camera Local Setting [ON/OFF]  
Image parameters can be set up independently for each preset. There are 2 modes, "Global" mode & "Local" mode. The Global mode is that parameters are set up totally and simultaneously for all presets. The Global parameters setup can be done in "VIDEO" menu. The Local mode is that parameters are set up independently for each preset. Each Local parameter activate correspondingly when the camera arrives at each preset position. During jog operation, Global parameter should be applied. All Local parameters do not change although Global parameters changes.  
**① The sub-menu of Camera Local Setting depends on the model. Refer to the description of "Video Setup"**

## ❑ Preset Scene Setup

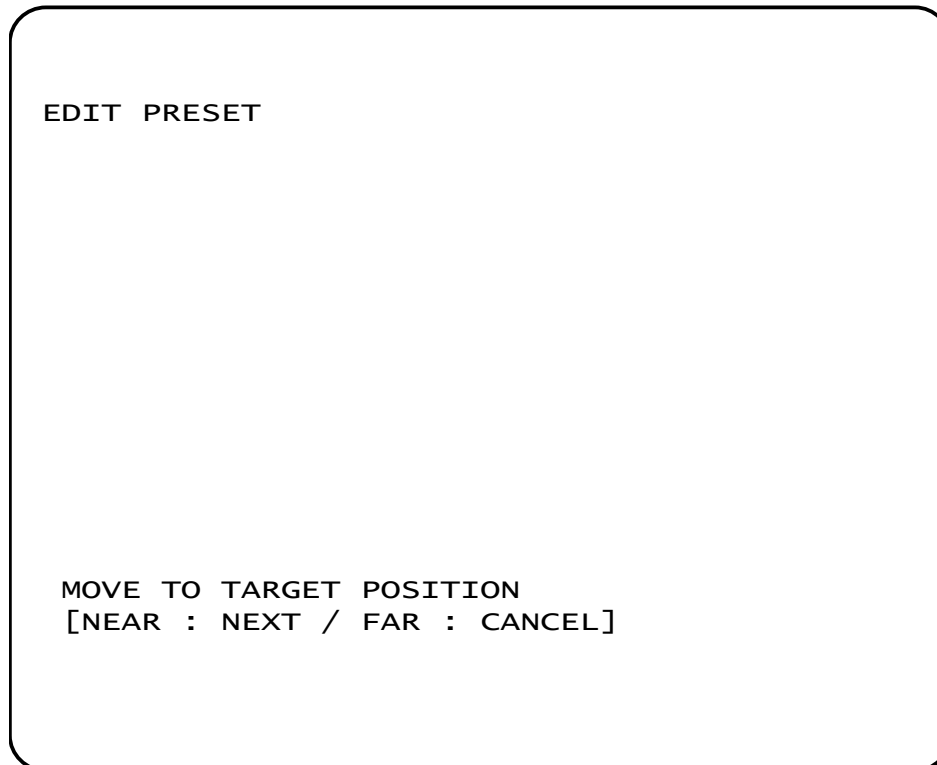

- ① Use the Joystick to move the camera to a desired position.
- ② Save the preset position by pressing **NEAR** key.
- ③ Press **FAR** key to cancel targeting the preset position.

## ❑ Preset Label Setup

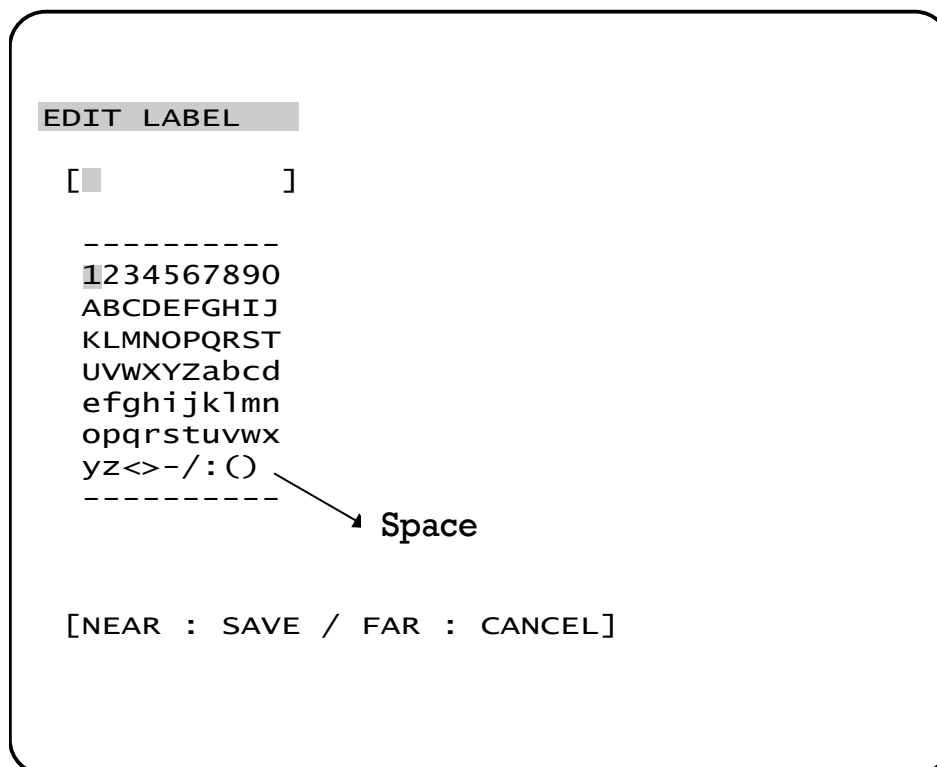

- ① As soon as finishing selecting an alphabet or a number, the cursor moves to the next digit.
- ② With **Left/Right/Up/Down** of the joystick, move to a desired character in the alphanumeric set. To select a desired character, press the **TELE** key. To clear current character and move to backward, press the **WIDE** key.
- ③ The end character in the alphanumeric set is space character.



## SWING Setup

```

SWING
SWING NO          1 UNDEFINED
- 1ST PRESET     1 UNDEFINED
- 2ND PRESET     1 UNDEFINED
- SWING SPEED    30/sec
CLEAR SWING      >
RUN SWING        >

```

- **Swing Number** [1~10]  
Selects a Swing number to edit. If the selected Swing is not defined, "UNDEFINED" is displayed.
- **1st Position** [PRESET 1~255]  
**2nd Position** Sets the 2 positions for a Swing function. If the selected preset is not defined, "UNDEFINED" is displayed.  
When a swing function runs, the camera moves from the preset assigned as the 1st point to the preset assigned as the 2nd point in CW(Clockwise) direction. Then the camera moves from the preset assigned as the 2nd point to the preset assigned as the 1st point in CCW (Counterclockwise) direction. In case that the preset assigned as the 1st point and the preset assigned as the 2nd point are same, the camera turns on its axis by 360° in CW direction and then it turns on its axis by 360° in CCW direction.
- **Swing Speed** [1°/sec. ~180°/sec.]  
Defines Swing speed between the 2 Preset positions from 1°/sec to 180°/sec
- **Clear Swing** Deletes the data of the selected Swing.
- **Run Swing** Runs Swing for the test purposes to check if it works properly.

## PATTERN Setup

```
PATTERN
PATTERN NO          1 UNDEFINED
CLEAR PATTERN      >
RUN PATTERN        >
EDIT PATTERN       >>
```

- Pattern No [1~4]  
Selects a Pattern number to edit. If the selected pattern number is not defined, "UNDEFINED" will be displayed.
- Clear Pattern Deletes the data of the selected pattern.
- Run Pattern Runs the Pattern for the test purposes to check if it works properly.
- Edit Pattern Edits the selected pattern.

## □ Edit Pattern

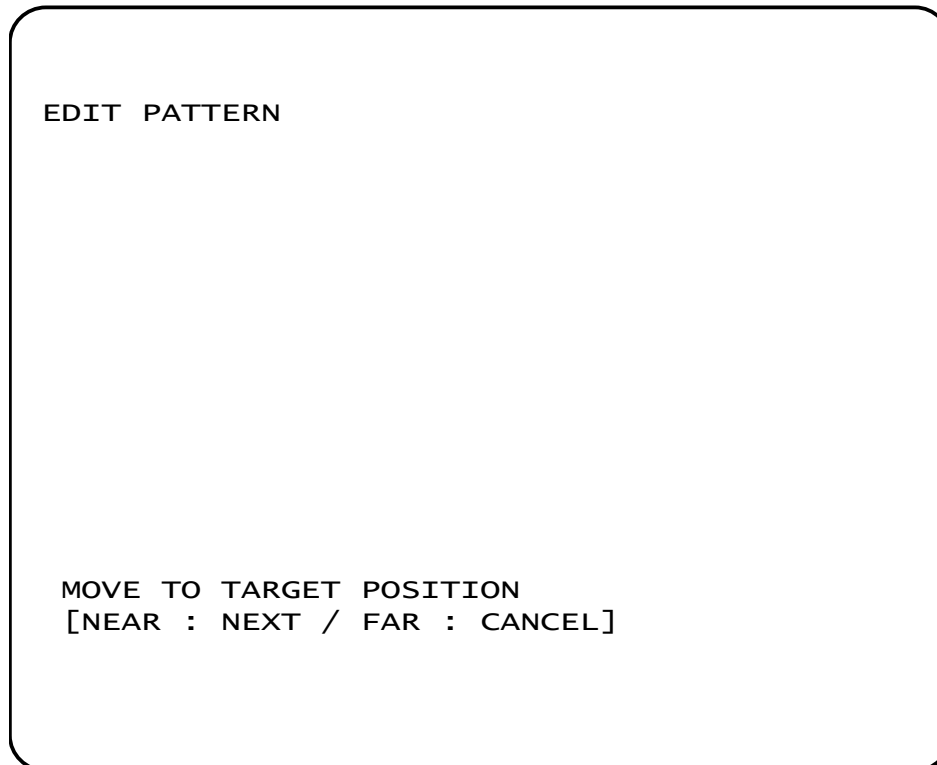

- ① With the Joystick of your controller, move the camera to the start position with an appropriate zoom magnification. To start the pattern recording, press **NEAR** key. To exit, press **FAR** key.

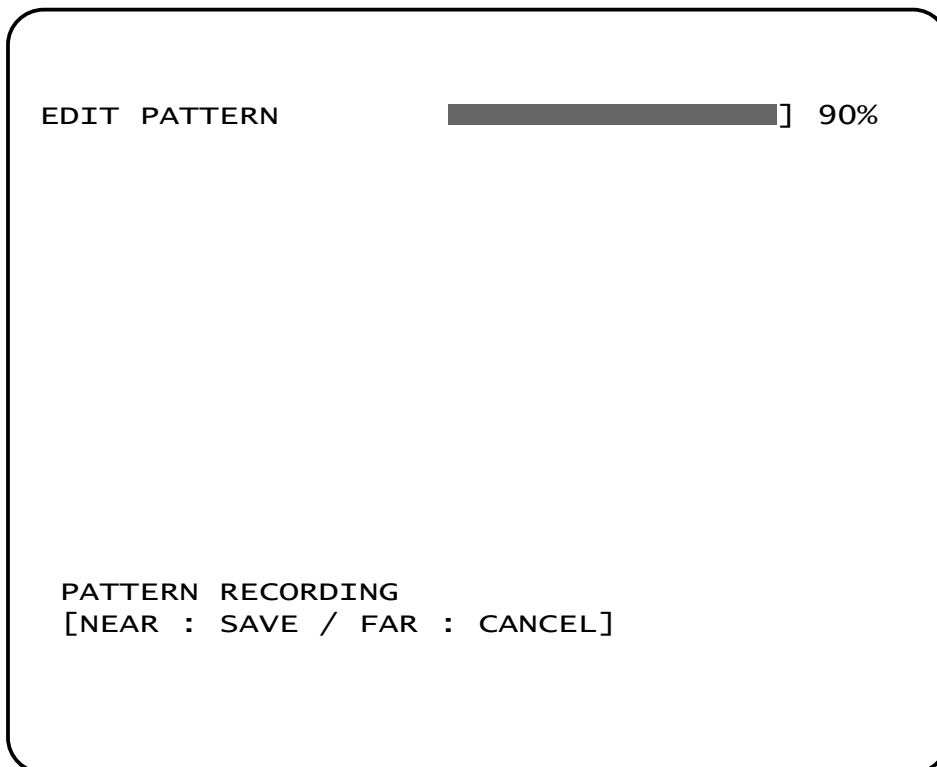

- ② Move camera with joystick of controller to memorize the path (mostly curve path) in the selected pattern. The movement by Joystick will be memorized in a pattern. After a pattern is programmed, the remaining storage is displayed in progress bar on the screen.
- ③ To save the data and exit, press **NEAR** key. To cancel saving the data and delete the data, press **FAR** key.

## GROUP Setup

GROUP						
GROUP NO				1	UNDEFINED	
CLEAR GROUP				>		
RUN GROUP				>		
-----						
NO	ACTION	TYPE	ACTION	NO	DWELL	OPTION
-----						
1	UNDEFINED		1		00:05	-
2	UNDEFINED		1		00:05	-
3	UNDEFINED		1		00:05	-
4	UNDEFINED		1		00:05	-
5	UNDEFINED		1		00:05	-
6	UNDEFINED		1		00:05	-
7	UNDEFINED		1		00:05	-
8	UNDEFINED		1		00:05	-
9	UNDEFINED		1		00:05	-
10	UNDEFINED		1		00:05	-
[FAR : MOVE TO TOP]						

- **Group No** [1~8]  
Selects a Group number to edit.  
If the selected Group number is not defined, "UNDEFINED" will be displayed.
- **Clear Group** Deletes the data of the selected Group.
- **Run Group** Runs the Group for the test purposes to check if it works properly.
- **Action Type** [UNDEFINED/PRESET/SWING/PATTERN]  
**Action No** Selects the actions to execute. MAX. 40 actions are allowed in a Group.
- **Dwell** [0 SEC. ~ 4 MIN.]  
Sets the Dwell Time between functions.
- **Option** Option. It is a preset speed when a preset is selected in the Action. It is the number of repeat when a Pattern or a Swing is selected in the Action.

Press the **FAR** key to move the cursor position to "Group No" after edit of actions is complete.

## ALARM TRIGGER Setup

### ALARM TRIGGER

ALARM NO	1
ALARM TYPE	NORMAL OPEN
TRIGGERED ACTION	UNDEFINED
TRIGGERED ACTION NO	-
TRIGGERED HOLD TIME	ENDLESS
POST ACTION	HOME
POST ACTION NO	-

- Alarm No [1~3]  
Selects a sensor number to set up.
- Type [NORMAL OPEN/ NORMAL CLOSE]  
Selects sensor operation type.
- Triggered Action [UNDEFINED/PRESET/PATTERN/SWING/GROUP]  
/ Action No Selects an action to run when a sensor signal is input.
- Hold Time [ENDLESS / 1~59 SEC. / 1~180 MIN.]  
Sets the time period for the action which is run by external sensor activation. After the time period passes, the action pre-defined in “Post Action” runs sequentially in succession to the action by external sensor activation. If this option is set to “ENDLESS”, “Post Action” does not activate.
- Post Action / [HOME/PRESET/PATTERN/SWING/GROUP/PREV ACTION]  
Post Action No Selects the action that a camera will run after the time period in “HOLD TIME” passes. If Post Action is set to “PREV. ACTION”, the camera runs the previous action which it ran most recently.

## SCHEDULE Setup

### SCHEDULE

SCHEDULE NO	1
SCHEDULED ACTION	UNDEFINED
SCHEDULED ACTION NO	-
SCHEDULED HOLD TIME	ENDLESS
POST ACTION	HOME
POST ACTION NO	-
ACTION CYCLE	ONCE
- YEAR	2012
- MONTH	JAN
- DAY	1
- HOUR	0
- MINUTE	0
- SECOND	0

- Schedule No [1~8]  
Selects a Schedule to be configured.
- Action / Action No [UNDEFINED/PRESET/PATTERN/SWING/GROUP]  
Configures a function to be run for a configured time period.
- Hold Time [ENDLESS / 1~59 SEC. / 1~180 MIN.]  
Configures a time period to run an Action. After this time passes, "Post Action" should run. If Post Action is configured to ENDLESS, Post Action should not run.
- Post Action / Post Action No [HOME/PRESET/PATTERN/SWING/GROUP/PREV ACTION]  
Configures a function to be run after a Hold Time. When "PREV. ACTION" is configured, the latest function which is running just before a Schedule Function should keep running again.
- Cycle [ONCE/HOURLY/DAILY/WEEKLY/MONTHLY]  
Configures a time period to repetitively run a Schedule Function. If "ONCE" is configured, a Schedule function should run once and it should not run again.
- Time  
Configures a Date and a Time to run a Schedule Function.

## OSD Setup

```

VIDEO
PTZ
ACTION
OSD      DISP CAMERA ID      ON
SYSTEM  DISP ALARM I/O      AUTO
INFORMATION  DISP PTZ INFO      AUTO
          DISP ACTION TITLE  AUTO
          DISP PRESET LABEL  AUTO
          DISP TIME          ON
          DISP DATE          ON

```

OSD setup allows you to program how labels are displayed on the monitor. In case of AUTO, the labels are displayed on the monitor when there are any changes in parameters.

- Camera ID [ON/OFF]  
Displays the selected Camera ID.
- Alarm I/O [ON/OFF/AUTO]  
Displays the activated alarms. This information shows the current state of Alarm Inputs and Relay Outputs. If an Input point is **ON** state, it will show a number corresponding to each point. If an Input point is **OFF** state, '-' will be displayed.
- PTZ Information [ON/OFF/AUTO]  
Displays the positions of pan/tilt, zoom magnification.
- Action Title [ON/OFF/AUTO]  
Identifies Actions.  
"PRESET xxx", "PATTERN x", "SWG x-PRESET xxx", "UNDEFINED"
- Preset Label [ON/OFF/AUTO]  
Displays the preset labels when the camera arrives at presets.

- 
- **Display Date** [ON/OFF]  
Configures whether Date will be displayed in OSD or not.
  - **Display Time** [ON/OFF]  
Configures whether Time will be displayed in OSD or not.



## SYSTEM Setup

```

VIDEO
PTZ
ACTION
OSD
SYSTEM
INFORMATION
LANGUAGE
TIME SETTING
HEATER SETTING
ENABLE PASSWORD
EDIT PASSWORD

FACTORY RESET
- RESET VIDEO
- RESET PTZ
- RESET ACTION
- RESET OSD
REBOOT SYSTEM

ENGLISH
>>
AUTO
OFF
>>

>
>
>
>
>
>

```

- Heater Setting [AUTO/ON/OFF]  
Configures how Heater works. If this is set to “AUTO”, an internal sensor detects internal temperature and Heater automatically starts working or stops working according to internal temperature change.
- Enable Password [ON/OFF]  
Configures whether OSD menu will be protected with a password.
- Factory Reset  
Deletes all configuration data and the system is set to the factory default. If the Factory Reset is selected, a message asks for the final confirmation. Press the **NEAR** button for the final confirmation.
- Reset Video  
Initializes all the configuration data for VIDEO menu.
- Reset PTZ  
Initializes all the configuration data for PTZ menu.
- Reset Action  
Initializes all the configuration data for ACTION menu.
- Reset OSD  
Initializes all the configuration data for OSD menu.
- Reboot System  
Reboots the system.

❑ Factory Default

● Video Menu Setting (30S, 20S Model)			
Focus Mode	SEMIAUTO	Day&Night	AUTO
White Balance	AUTO	Digital Zoom	ON
Exposure Mode	AUTO	Image Flip	OFF
BLC	OFF	Stabilization	OFF
WDR	OFF	Privacy Mask	UNDEFINED
Auto DSS	ON	HD-SDI Resolution	1080p30 (NTSC)
Aperture	12		1080p25 (PAL)

● Video Menu Setting (30T, 20T, 19T Model)			
Focus Mode	SEMIAUTO	Sharpness	12
White Balance	AUTO	Day&Night	AUTO
Shutter	ESC	Digital Zoom	ON
Iris	AUTO	Image Flip	OFF
Gain	MEDIUM	Stabilization	OFF
Brightness	50	Privacy Mask	UNDEFINED
Backlight	OFF	HD-SDI Resolution	1080p30 (NTSC)
Sens-Up	Auto x2		1080p25 (PAL)
SSNR	MEDIUM		

● Video Menu Setting (20W Model)			
Focus Mode	SEMIAUTO	Aperture	8
White Balance	AUTO	Day&Night	AUTO
Exposure Mode	AUTO	Digital Zoom	ON
BLC	OFF	Image Flip	OFF
WDR	OFF	Privacy Mask	UNDEFINED
Defog	OFF	HD-SDI Resolution	1080p30 (NTSC)
Auto DSS	ON		1080p25 (PAL)

● Video Menu Setting (28L, 30L Model)			
Focus Mode	SEMI-AUTO	Color	ON
White Balance	AUTO	Color Level	0
Iris	AUTO	EIS	OFF
AGC	30	Day&Night	AUTO
Brightness	50	Digital Zoom	ON
Shutter mode	AUTO	Image Flip	OFF
Sens-Up	OFF	Privacy Mask	UNDEFINED
3DNR	MEDIUM	HD-SDI Resolution	1080p30 (NTSC)
WDR/BLC	OFF		1080p25 (PAL)
Sharpness	34		

● PTZ Menu Setting		● ACTION Menu Setting	
Power Up Action	ON	Motion Edit Lock	OFF
Auto Parking	OFF	Preset	UNDEFINED
Auto Flip	ON	Swing	UNDEFINED
Jog Max Speed	120°/sec	Pattern	UNDEFINED
Jog Direction	INVERSE	Group	UNDEFINED
Zoom Proportional Jog	ON	Alarm Trigger	UNDEFINED
Freeze In Preset	OFF	Schedule	UNDEFINED
● OSD Menu Setting		● SYSTEM Menu Setting	
Disp Camera ID	ON	Time	01/JAN/2012
Disp Alarm I/O	AUTO		00:00:00
Disp PTZ Info	AUTO	Heater Setting	AUTO
Disp Action Title	AUTO	Enable Password	OFF
Disp Preset Label	AUTO	Password	Blank
Disp Time	ON		
Disp Date	ON		

**TIME Setup****TIME SETTING**

YEAR	2012
MONTH	JAN
DAY	1
HOUR	0
MINUTE	0
SECOND	0

Configure current date and time. HOUR does not support AM or PM form. HOUR can be configured in 24 hour form.

## PASSWORD Setup

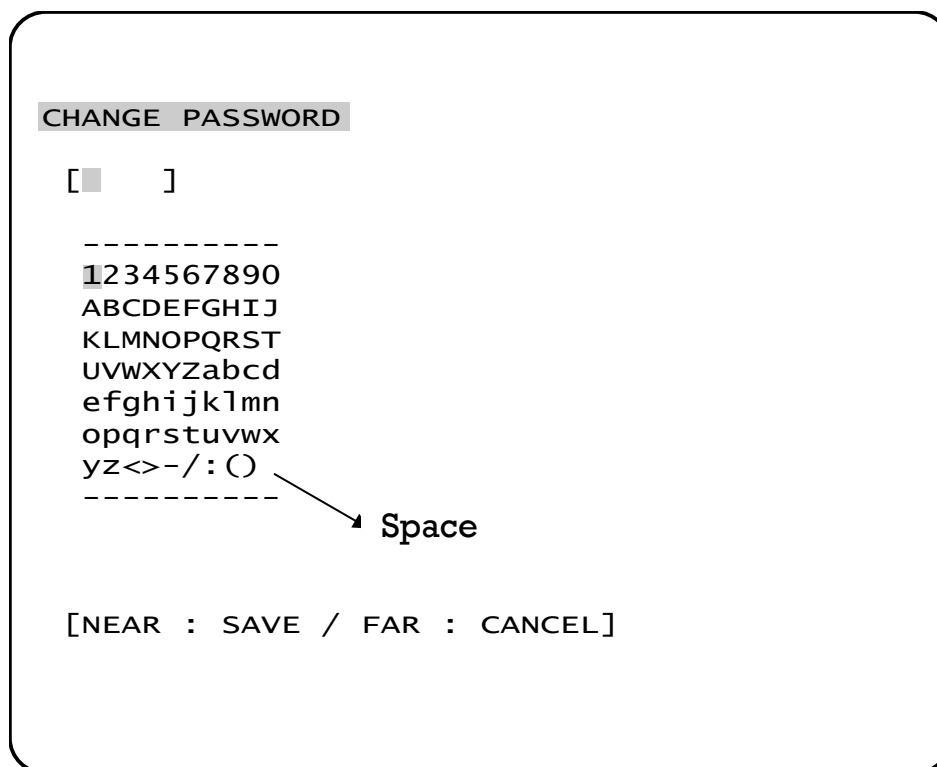

- ① As soon as finishing selecting an alphabet or a number, the cursor moves to the next digit.
- ② With **Left/Right/Up/Down** of the joystick, move to a desired character in the alphanumeric set. To select a desired character, press the **TELE** key. To clear current character and move to backward, press the **WIDE** key.
- ③ The end character in the alphanumeric set is space character.



[Caution] It is mandatorily recommended that a user must take a memo for a password before a user applies a password to a system. When a Password is forgotten, a unit can not be unlocked and the unit is supposed to be shipped back to the manufacturer.

## Specifications

<b>CAMERA PART (30S Model)</b>	
Image Sensor	1/2.8" Exmor CMOS Sensor
Pixels	3,270K pixels
Zoom	×30 Optical Zoom, ×12 Digital Zoom
Video Signal-to-Noise	50 dB
Focal Length	F1.6~4.7, f=4.61~138.3mm
Angle of View (H)	57.5°(Wide)~2.1°(Tele)
Min. Working Distance	10mm(Wide), 1200mm(Tele)
Zoom Speed	4.6 sec (Wide to Tele)
Minimum Illuminance	0.5 Lux (Color, 1/30sec, 50 IRE) 0.005 Lux (B/W, 1/4 or 1/3sec, 50 IRE)
Day & Night	Auto / Day / Night(ICR)
Focus	Auto / Manual / SemiAuto
AE Mode	Auto / Iris / Shutter / Manual / Brightness
White Balance	Auto / Manual(Red, Blue Gain Adjustable)
BLC	On / Off
WDR	On / Off
Aperture	Adjustable
NR	Yes
Privacy Zone	8 Masks, Spherical Coordinate
Stabilization	ON / OFF

<b>CAMERA PART (20S Model)</b>	
Image Sensor	1/2.8" Exmor CMOS Sensor
Pixels	3,270K pixels
Zoom	×20 Optical Zoom, ×12 Digital Zoom
Video Signal-to-Noise	50 dB
Forcal Length	F1.6~3.9, f=3.5~129.5mm
Angle of View (H)	55.4°(Wide)~2.9°(Tele)
Min. Working Distance	10mm(Wide), 1000mm(Tele)
Zoom Speed	2.3 sec (Wide to Tele)
Minimum Illuminance	0.5 Lux (Color, 1/30sec, 50 IRE) 0.005 Lux (B/W, 1/4 or 1/3sec, 50 IRE)
Day & Night	Auto / Day / Night(ICR)
Focus	Auto / Manual / SemiAuto
AE Mode	Auto / Iris / Shutter / Manual / Brightness
White Balance	Auto / Manual(Red, Blue Gain Adjustable)
BLC	On / Off
WDR	On / Off
Aperture	Adjustable
NR	Yes
Privacy Zone	8 Masks, Spherical Coordinate

<b>CAMERA PART (30T Model)</b>	
Image Sensor	1/4" PS CMOS Sensor
Pixels	1,300K pixels
Zoom	×30 Optical Zoom, ×12 Digital Zoom
Video Signal-to-Noise	50 dB
Forcal Length	F1.35~3.7, f=3.5~101.5mm
Angle of View (H)	H : 54.8°(Wide)~2.01°(Tele) / V : 44.6°(Wide)~1.61°(Tele)
Min. Working Distance	1500mm
Zoom Speed	3 sec (Wide to Tele)
Minimum Illuminance	1.5 Lux (Color, F1.6, 50 IRE) / 0. 1Lux (B/W, F1.6, 50 IRE)
Day & Night	Auto / Day / Night(ICR)
Focus	Auto / Manual / SemiAuto
White Balance	Auto / Manual(Red, Blue Gain Adjustable)
Iris	Auto / Manual
Gain	OFF / Low / Middle / High / Manual
Shutter Speed	Auto / Manual(×60~1/33,000) / A.FLK
BLC	OFF / BLC / HLC
SSNR	Low / Middle / High / OFF
Sens-Up	OFF / Auto (×2~×60)
Brightness	1~100
Sharpness	1~31
Privacy Zone	8 Masks, Spherical Coordinate
Stabilization	ON / OFF



<b>CAMERA PART (20T Model)</b>	
Image Sensor	1/3" PS CMOS Sensor
Pixels	2,000K pixels
Zoom	×20 Optical Zoom, ×8 Digital Zoom
Video Signal-to-Noise	50 dB
Forcal Length	F1.6~2.9, f=4.45~89mm
Angle of View (H)	H : 55.56°(Wide)~3.10°(Tele) / V : 43.32°(Wide)~2.34°(Tele)
Min. Working Distance	1000mm
Zoom Speed	3.3 sec (Wide to Tele)
Minimum Illuminance	1.5 Lux (Color, F1.6, 50 IRE) / 0. 1Lux (B/W, F1.6, 50 IRE)
Day & Night	Auto / Day / Night(ICR)
Focus	Auto / Manual / SemiAuto
White Balance	Auto / Manual(Red, Blue Gain Adjustable)
Iris	Auto / Manual
Gain	OFF / Low / Middle / High / Manual
Shutter Speed	Auto / Manual(×60~1/33,000) / A.FLK
BLC	OFF / BLC / HLC
SSNR	Low / Middle / High / OFF
Sens-Up	OFF / Auto (×2~×60)
Brightness	1~100
Sharpness	1~31
Privacy Zone	8 Masks, Spherical Coordinate
Stabilization	ON / OFF

<b>CAMERA PART (19T Model)</b>	
Image Sensor	1/3" PS CMOS Sensor
Pixels	1,300K pixels
Zoom	×19 Optical Zoom, ×16 Digital Zoom
Video Signal-to-Noise	52 dB
Forcal Length	F1.6~2.9, f=4.5~85.5mm
Angle of View (H)	H : 55.24°(Wide)~3.16°(Tele) / V : 44.96°(Wide)~2.542°(Tele)
Min. Working Distance	1000mm
Zoom Speed	3.3 sec (Wide to Tele)
Minimum Illuminance	0.7 Lux (Color, F1.6, 50 IRE) / 0.08 Lux (B/W, F1.6, 50 IRE)
Day & Night	Auto / Day / Night(ICR)
Focus	Auto / Manual / SemiAuto
White Balance	Auto / Manual(Red, Blue Gain Adjustable)
Iris	Auto / Manual
Gain	OFF / Low / Middle / High / Manual
Shutter Speed	Auto / Manual(×60~1/30,000) / A.FLK
BLC	OFF / BLC / HLC
SSNR	Low / Middle / High / OFF
Sens-Up	OFF / Auto (×2~×60)
Brightness	1~100
Sharpness	1~31
Privacy Zone	8 Masks, Spherical Coordinate
Stabilization	ON / OFF

<b>CAMERA PART (20W Model)</b>	
Image Sensor	1/3" Panasonic CMOS Sensor
Pixels	2,000K pixels
Zoom	×20 Optical Zoom, ×12 Digital Zoom
Video Signal-to-Noise	50 dB
Forcal Length	F1.6~3.5, f=4.7~94.0mm
Angle of View (H)	55.4°(Wide)~2.9°(Tele)
Minimum Illuminance	0.5 Lux (Color) 0.001 Lux (B/W, DSS)
Day & Night	Auto / Day / Night(ICR)
Focus	Auto / Manual / SemiAuto
AE Mode	Auto / Iris / Shutter / Manual / Brightness
White Balance	Auto / Manual(Red, Blue Gain Adjustable)
BLC	On / Off
WDR	On / Off
Defog	On / Off
Aperture	Adjustable
NR	Yes
Privacy Zone	8 Masks, Spherical Coordinate

<b>CAMERA PART (30L Model)</b>	
Image Sensor	1/2.8" CMOS Sensor
Pixels	3,270K pixels
Zoom	×30 Optical Zoom, ×12 Digital Zoom
Forcal Length	F1.6~5.0, f=4.3~129.0mm
Minimum Illuminance	0.8 Lux (Color, Sens-up Off) / 0.1 Lux (B/W, Sens-up Off)
Day & Night	Auto / Day / Night(ICR)
Focus	Auto / Manual / SemiAuto
Iris	Auto / Manual
Shutter Speed	Auto / Manual(×32~1/10,000) / A.FLK
AGC	0 ~ 30
White Balance	Auto / ATW / Manual(Red, Blue Gain Adjustable. 1700°K~11000°K)
BLC	WDR/ BLC / OFF
DNR	Low / Middle / High / Off
Privacy Zone	8 Masks, Spherical Coordinate
Stabilization	ON/OFF

<b>CAMERA PART (28L Model)</b>	
Image Sensor	1/4" CMOS Sensor
Pixels	1.3M pixels
Zoom	×28 Optical Zoom, ×12 Digital Zoom
Forcal Length	F1.5~3.7, f=3.5~98.0mm
Minimum Illuminance	0.8 Lux (Color, Sens-up Off) / 0.01 Lux (B/W, Sens-up Off)
Day & Night	Auto / Day / Night(ICR)
Focus	Auto / Manual / SemiAuto
Iris	Auto / Manual
Shutter Speed	Auto / Manual(×32~1/10,000) / A.FLK
AGC	0 ~ 30
White Balance	Auto / ATW / Manual(Red, Blue Gain Adjustable. 1700°K~11000°K)
BLC	WDR/ BLC / OFF
DNR	Low / Middle / High / Off
Privacy Zone	8 Masks, Spherical Coordinate
Stabilization	ON/OFF

MECHANISM PART		
Movement Range	Pan	360°(Endless)
	Tilt	90°
Speed	Preset	500°/sec.
	Jog	0.05 ~ 360°/sec. (Proportional to Zoom)
	Swing	10~ 180°/sec.
Preset	209 Presets (Label, Independent Camera Parameter Setting)	
Pattern	4 Patterns [768 Commands(Approx. 5 Minute) / Pattern]	
Swing	10 Swings	
Group	8 Groups (MAX. 40 Actions with The Combination of Preset, Pattern and Swing)	
Schedule	8 Schedules	
Other Pan/Tilt Functions	Auto Flip, Auto Parking, Power Up Action and etc.	
Video Ouput	2×BNC (HD-SDI and CVBS)	
HD-SDI	HDcctv v1.0, 1.485Gb/s, SMPTE 292M standard Resolution : 1080p/30/25, 1080i/60/50, 720p/60/50/30/25	
CVBS	1Vp-p	
Real Time Clock	Yes, RTC battery backup time : 2 weeks	
Communication	RS-485	
Protocol	Pelco-D, Pelco-P Selectable	
OSD	English Menu / Time / PTZ information etc, Password protection	
Sensor Input	3 Inputs, Photo-Coupler Type, DC 5V~12V	
Alarm Outputs	1 Output, Relay Output, MAX. Load DC24V 1A / AC125V 0.5A	
Fan *	Always ON	
Heater *	Operation Start from Internal Temperature 10°C	
Operation Temperature	In-Ceiling model : 0°C ~ 40°C Others : -30°C ~ 50°C	
Rated Power	In-Ceiling model : DC 12V / 1.3A or AC 24V / 1.0A Others : DC 12V / 1.8A or AC 24V / 2.0A	

**\* In-ceiling model does not support Fan/Heater functions.**

<b>MECHANICAL</b>				
		Ceiling Mount	Wall Mount	In-Ceiling Mount
Material	Dome	Polycarbonate		
	Internal	Polycarbonate, ABS		
	External	Aluminium		Polycarbonate
Dome Size		Ø150mm / Ø 5.9"		
Dimension		Ø200×407.8 mm	300×309.1 mm	Ø253×259 mm
Weight		Approx 3.6 Kg	Approx 3.4 Kg	Approx 2.3 Kg

**[Note]**

- 1) Specification and features are subject to change without prior notice.**
- 2) Specification and features are different by models.**
- 3) Check the voltage and current capacity of rated power carefully.**

**Dimension**

● Main Body

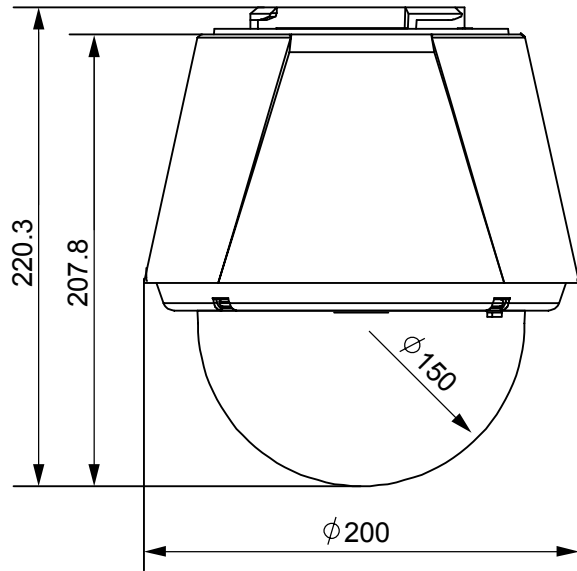

● Ceiling Mount Type

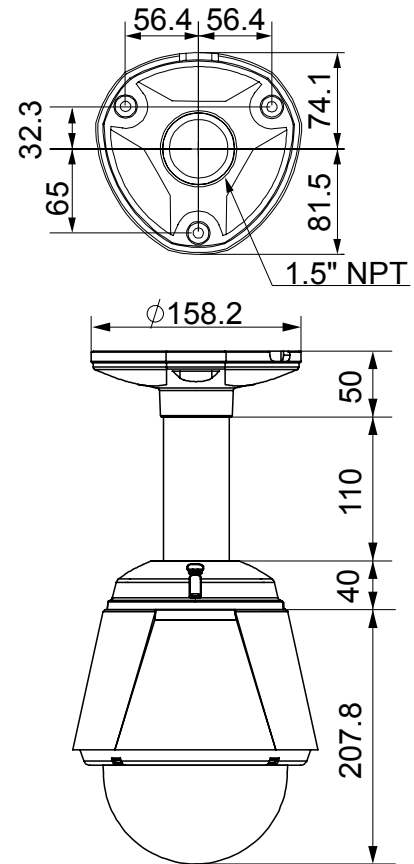

● Wall Mount Type

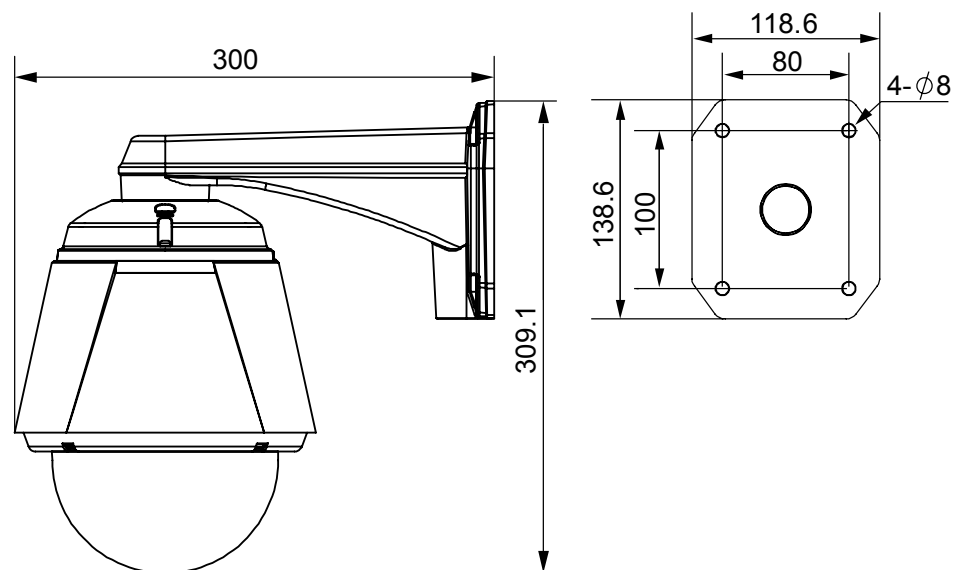

● In-Ceiling Mount Type

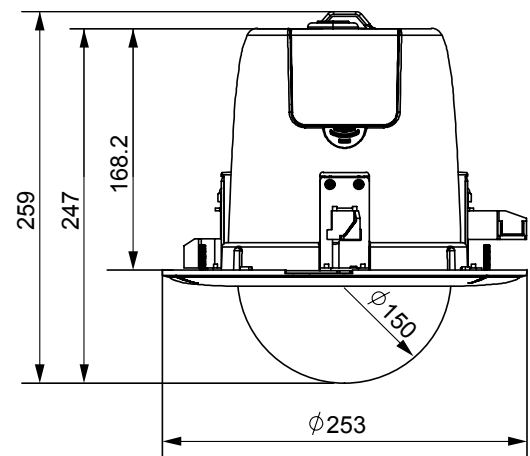

[Unit : mm]