

**IP Camera**  
**Operation Manual**  
**V2.2.0**

**March 5, 2014**

# Preface

Thank you for buying our product very much.

## Description

- This operation manual takes a gun-type IP camera as an example, and describes the operation method and performance index of the IP camera in detail.
- The IP camera mentioned in the text refers to the IP camera.
- The IP address of the IP Camera in the text sets the network parameter by taking 192.168.1.100 as an example.
- Before using the IP Camera, we advise you to read this operation manual carefully, install and use this system according to the steps described in the manual.
- The bold typeface in the text is the part which needs special attention.

## Statement

**This manual may include inexact part technically, or the part unmatched with the product function, or the part with wrong printing. We will update the content of this manual according to the enhancement of the product function, and improve or update the product or procedure described in this manual regularly. The updated content will be added in the new version of this manual without notice.**

# Safety Instructions

This content aims to ensure that user can use this product correctly in order to avoid risk or financial loss. Before using this product, please carefully read this operation manual and carefully store it for future reference.

As shown below, the precautionary measures are divided into “warning” and “notice”:

**Warning:** it may cause serious injury for ignoring the warning matters.

**Notice:** it may cause the financial loss if ignoring the matters needing attention.



## **Warning:**

1. Please use the power source which satisfies the requirement of safe low-voltage, and make sure rated voltage of the limited power source is 12 V DC supply.
2. If the equipment cannot work normally, please contact the service center where you bought this device or the service center nearby, do not dismantle or change the device in any way (user shall be responsible for the problems caused by change or repair without permission)
3. In order to reduce fire disaster or shock hazard, prevent this product from raining or wetting.
4. This installation should be carried out by professional service staff, and shall accord with the provisions by local laws and regulations.



## **Notice**

5. Before running the camera, please check whether the power supply is correct.
6. Do not throw the product on the ground or seriously strike it.
7. Do not contact the optical element of the image sensor directly; if it is necessary to clean, please wipe the dust by a clean soft cloth after being wetted by high concentration ethanol; when the camera is not in use, please cover it with the anti-dust cover.
8. Avoid wet, dusty, extremely hot, extremely cold (normal working temperature: 10 below DEG C-70 DEG C), strong electromagnetic radiation, and other places.
9. Prevent water and any fluid from flowing into **IP Camera** in use.
10. When **IP Camera** is conveyed, package it by the pack or the material with the same quality when it leaves factory

## Contents

PREFACE .....	1
1 PRODUCT OVERVIEW .....	4
1.1 MAIN FUNCTION AND CHARACTERISTICS .....	4
1.2 APPLICATION FIELD .....	5
2 APPEARANCE AND INSTALLATION .....	5
2.1 RUNNING ENVIRONMENT OF PC .....	5
2.2 APPEARANCE STRUCTURE OF IP CAMERA AND DEFINITION OF INTERFACE .....	6
2.3 TOPOLOGICAL GRAPH OF CAMERA CONNECTION .....	7
3 IP CAMERA ACCESS .....	9
3.1 PC NETWORK SETTING .....	9
3.2 ACCESS THROUGH IE BROWSER .....	11
3.3 ACCESS THROUGH CLIENT .....	15
4 IP CAMERA PARAMETER SETTING .....	18
4.1 LOCAL SETUP .....	18
4.2 NETWORK SETUP .....	20
4.3 VIDEO CODING SETTING .....	25
4.4 COLOR SETTING .....	26
4.5 CHARACTER SUPERIMPOSITION AND SHADE .....	27
4.6 PTZ .....	29
4.7 VIDEO MOBILE ALARM .....	31
4.8 ALARM INPUT .....	33
4.9 ALARM LINKAGE .....	35
4.10 SYSTEM SETUP .....	39
4.11 USER RIGHT .....	44
4.12 RECORD MANAGEMENT .....	45
5 WIRELESS ACCESS .....	48
5.1 ACCESS THROUGH WIFI .....	48
5.2 ACCESS THROUGH MOBILE PHONE .....	50
5.3 ACCESS THROUGH 3G .....	51
6 WAN ACCESS .....	52
6.1 ACCESS THROUGH DDNS .....	52
6.2 ACCESS THROUGH P2P .....	53
APPENDIX I PORT MAPPING METHOD .....	54
APPENDIX II MYEYE .....	55
APPENDIX III EX-FACTORY DEFAULT PARAMETER OF EQUIPMENT .....	56
APPENDIX IV COMMON TROUBLESHOOTING INSTRUCTIONS .....	57

# 1 Product Overview

The IP Camera adopts an embedded RTOS design; it has high sensitivity; the snapped moving image is free from sawtooth; it has pure hard compression, watchdog, stability and reliability, and extremely low power consumption. The IP Camera is completely separated from the PC platform, and the system scheduling efficiency is high; the code is solidified in FLASH, thus the system running is more stable and reliable.

By adopting the advanced H264 compression technology, the IP Camera is able to compress the video signal; the compressed data can be transmitted. Through the network, user can perform the real-time video and sound preview; it supports ONVIF 2.0 international GB 28181 protocol, stream protocol (RTP/RTCP, RTSP), IE browse, full-duplex speech talkback, multi-linguistic support, “my E-version” function, and PUSH ALARM phone alarm function.

## 1.1 Main function and characteristics

### Basic function

Adopt advanced H264 compression technology; the compression ratio is high and the treatment is very flexible;

- Support the on-line monitoring of multiple users at the same time; support C/S model; the built-in embedded type Web server of IP Camera can provide convenient B/S model access for you;
- Multi-user privilege management can ensure the safety of the system;
- Support one RS-485 interface (optional), support the PTZ equipment of the third party or the other serial equipment, and support the transparent transmission;
- Powerful alarm management and affair handling ability; the video lost, video movement alarm, probe input, alarm output, alarm linkage, automatic connection of alarm, and alarm log can help you to handle various emergencies easily; I path of switching value triggers the alarm input, and 1 path of probe triggers the alarm output.

### Compressing function

- IP Camera supports 1 path of sound video signal and can compress the image with the highest resolution with 25 frames above per second in real time; by adopting the H264 compression standard, the code stream control can be carried out by two methods of fixing code stream and fixing quality. When the video image quality is set, the compression code stream of the video image can be defined;
- Support three-code stream, main code stream, sub-code stream, and phone code stream;
- Support OSD, set the position of the described information, multiple displaying styles of date and time;
- Support at most five video shield and set video shield at any position in the video image;

### Network function

- Support one 10M/100M compatible Ethernet port;
- Support TCP/IP protocol, set parameter through application software or IE browser, browse video and audio signals in real time, check IP Camera state; perform the network alarm, and

- store the compression code stream through network;
- Network controls the rotation of a holder and relevant parameter of the camera, such f-number, and distance of focal length, etc;
  - Upgrade through network Setingly and achieve Seting maintenance;
  - Support RTSP/RTP/CGI/FTP/PPPOE/DHCP/DDNS/NTP/UPnP, and other network protocols.
  - Support ONVIF 2.2 international GB 28181 protocol, compatible with NVR of domestic and foreign standard ONVIF protocols; compatible with monitoring software of domestic and foreign standard ONVIF protocols.
  - Support PUSH ALARM phone pushing function, and check alarm video through mobile phone at any time.
  - Support IMAC system monitoring, support the monitoring of iPhone, Android, Saipan, Blackberry, and other mobile phones, support Seting configuration of mobile phone, local video, local playback, and other functions.
  - Support “my E-version”, and access device through network at any time and any place.
  - Support operations of Firefox, Chrome, and other browsers.

## 1.2 Application Field

It is suitable for various fields where the network Seting monitoring is required, e.g.

- Network monitoring of ATM, bank teller, supermarket, factory, and other places
- Seting monitoring service provided for nursing home, kindergarten, and school
- Smart access control system
- Smart mansion, intelligent residential district management system
- Unattended operation system of electric power station and telecom base station
- Outdoor equipment monitoring management
- Traffic status monitoring system of bridge, tunnel, and intersection
- Monitoring of production line, supervision of storehouse
- Supervision of road traffic for 24 hours
- Seting monitoring of forest, water source, river resource
- Other application field

# 2 Appearance and Installation

## 2.1 Running environment of PC

The PC working environment of IP Camera is defined as follows:

### **The lowest configuration of PC hardware environment**

CPU: Pentium dual-core 1.6GHz

Memory: 1024 MB

Display card: NVIDIA GeForce GT210

Sound card: it needs voice monitoring; and it is necessary during the duplexing talkback

Hard disk: if the image is required to record, the image should not be less than 40G

### Recommended configuration of PC hardware environment

CPU: Inter® Core™ i3 2.5Ghz above

Memory: 2048 MB above

Display card: NVIDIA GeForce GT520 above

Hard disk: 500 G

### PC operation system

Support 32/64bit Windows2000/XP/2003/VISTA/WIN7/WIN8 operation systems in Chinese/English.

Support IMAC system.

### Software environment

Support IE6,IE7, IE8, IE9,IE10,IE11 versions

DirectX9.0 above version

TCP/IP network protocol

Please pay attention to the following matters at the same time during the installation and operation:

- 1) Please carefully check the package box when it is opened, and confirm that the matters therein are in accordance with the list;
- 2) Please carefully read the operation manual before installation;
- 3) When the IP Camera is installed, please do close power sources of all relevant devices;
- 4) Check the supply voltage and prevent the equipment damage caused by unmatched voltage.
- 5) Installing environment: do not use it under wet or hot environment, keep good ventilation, and prevent the ventilation opening from being blocked. Horizontal place it and avoid the installation under the serious shocking environment.

## 2.2 Appearance structure of IP Camera and definition of interface

### 2.2.1 Definition of panel interface

- 1) The definition of panel interface of the gun-type IP Camera, which is shown as Figure 2-2-1

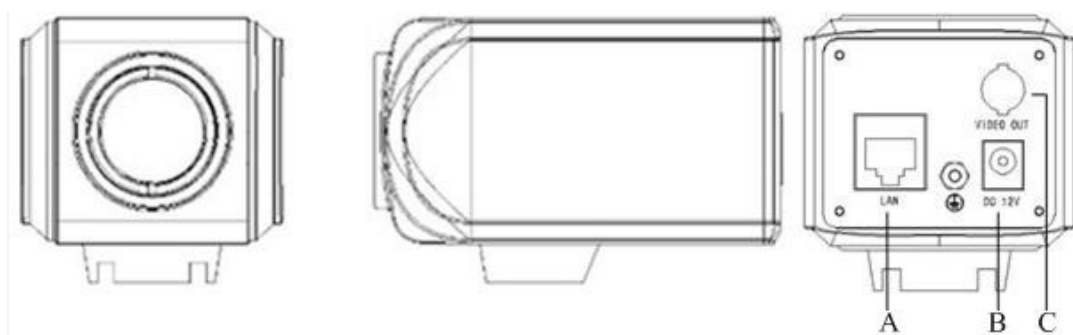

Figure 2-2-1 Gun-type panel interface

**Introduction of interface:**

- A. 『LAN』 standard network RJ 45 interface
- B. 『DC12V』 power interface, which is connected with 12 V DC power through a voltage stabilizer; please use a matched power supply of the voltage stabilizer
- C. 『VIDEO OUT』 analog video output interface, standard BNC interface

**2) Definition of panel interface of infrared waterproof, fixed hemisphere, spherical IP Camera, which is shown as Figure 2-2-2:**

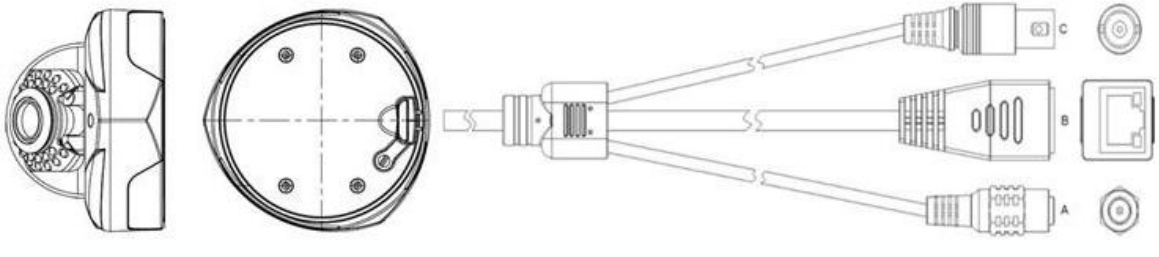

Figure 2-2-2 Infrared and hemisphere panel interfaces

**Introduction of interface:**

- A. 『DC12V』 power interface, which is connected with 12 V DC power through a voltage stabilizer; please use a matched power supply of the voltage stabilizer
- B. 『LAN』 standard network RJ45 interface
- C. 『VIDEO OUT』 analog video output interface, standard BNC interface

## 2.3 Topological graph of camera connection

There are two common-used connection methods between the IP Camera and the computer, and the methods are shown as Figure 2-3-1 and 2-3-2:

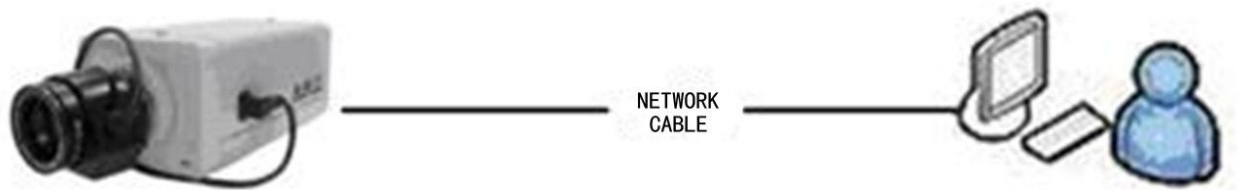

Figure 2-3-1 Direct connection through a network cable



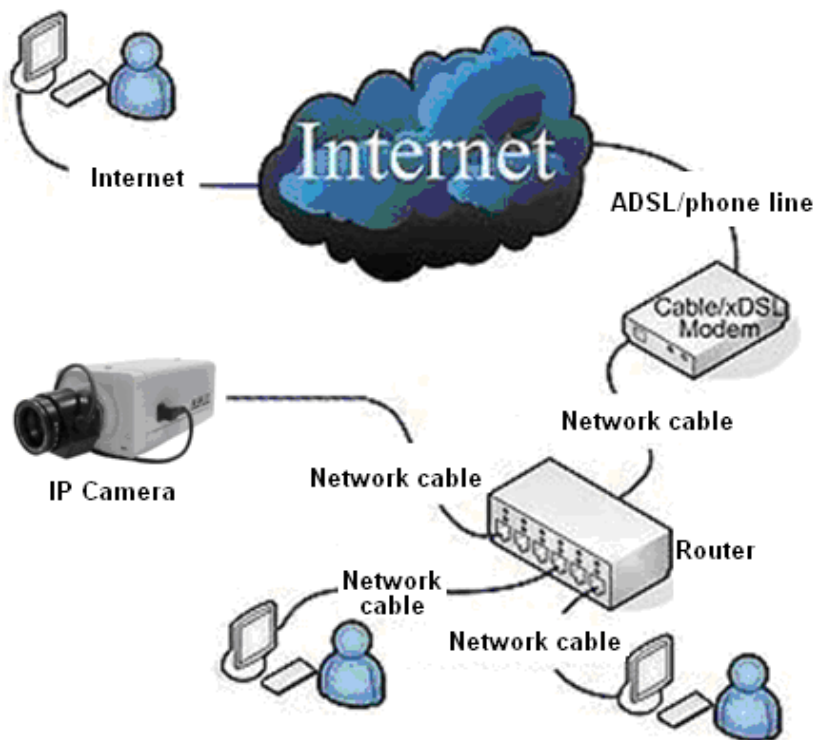

Figure 2-3-2 Connection through an exchange and a router



**Notice: when the power supply connected by POE, do not access IP Camera by using a 12V adapter; otherwise, it is likely to cause the equipment damage.**

Before accessing the IP Camera through network, obtain IP address thereof at first; search the IP address of the network camera through the SearchTools software.

By running the SearchTools V2 software in the random optical disk, the software will automatically display the IP address, port number, subnet mask, MAC address, DHCP state and version information, and so on of the running IP Camera in the current LAN; it is shown as Figure 2-3-3:

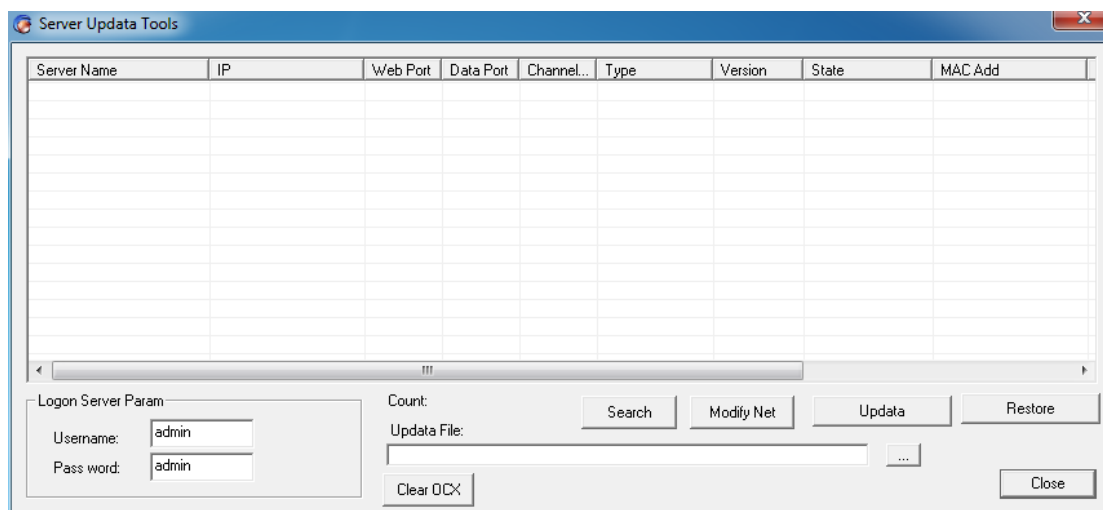

Figure 2-3-3 Search IP address

## 3 IP Camera Access

### 3.1 PC network setting

The defaulted IP address of IP Camera:DHCP, Direct Connect IP: 192.168.1.100. Add an IP address capable of accessing IP Camera mutually to the computer, for example:

◆ 192.168.1.99, the specific operation method is as follows:

#### If you use Windows 2003/XP operation system:

After entering the operation system, click [Start] → [Set] → [Control panel] of the task bar; open “Network and Dial connection” menu, click the mouse once and select the “Local Connection” icon corresponding to the network card connected with the video server; click right button once and select “Property”; select “Internet Protocol (TCP/IP)” from the popup “Routine” page, check “Property”, and pop up the following page, shown as Figure 3-1-1:

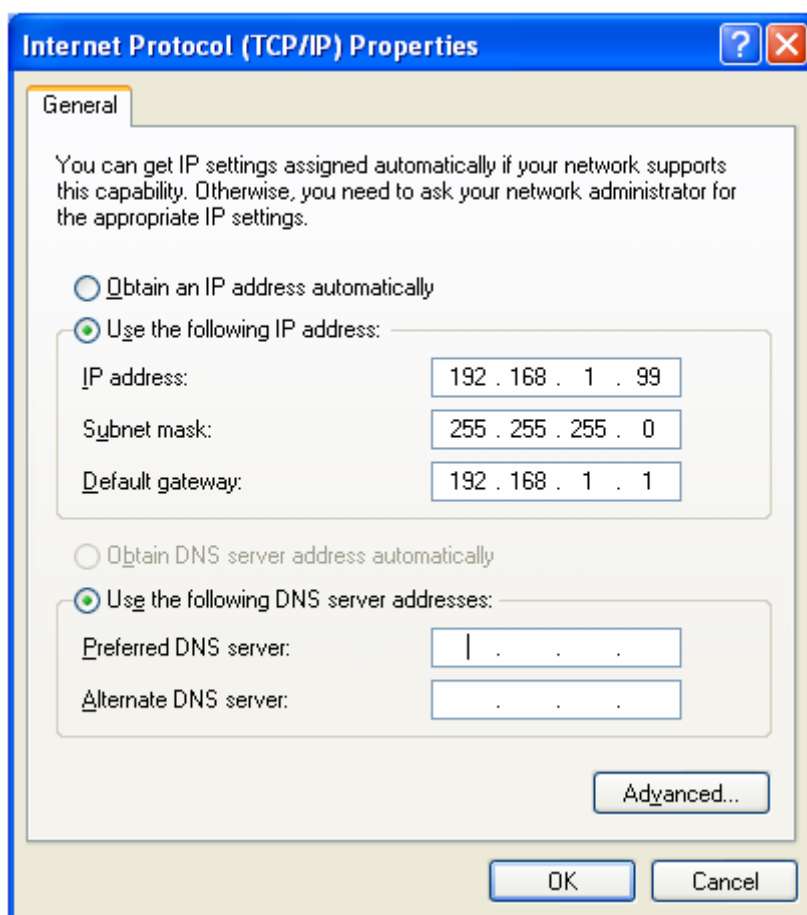

Figure 3-1-1 Set network parameter of computer

Select the “Use the following IP address”, and fill the IP address **192.168.1.99** (the other IP address which is not conflict with 192.168.1.100 in the same one network segment); the subnet mask is 255.255.255.0, and defaulted gateway is 192.168.1.1. The others are not required to set;

click “Confirm” on this page and the “Confirm: on the page of “Local connection property”. Wait for the configuration of the system.

**If you use Windows Vista /Window 7 operation system:**

After entering the operation system, click [Start] →[Control panel] of the task bar, open “Network and Share center” and select “Network connection”; click mouse once and select the “Local Connection” icon corresponding to the IP Camera network card connecting the IP Camera; click the right button and select “Properties”; select “Internet Protocol Version 4 (TCP/IPv4)” from the popped page “Local connection property”, check “Properties”, and pop up the following pages, and show as Figure 3-1-2:

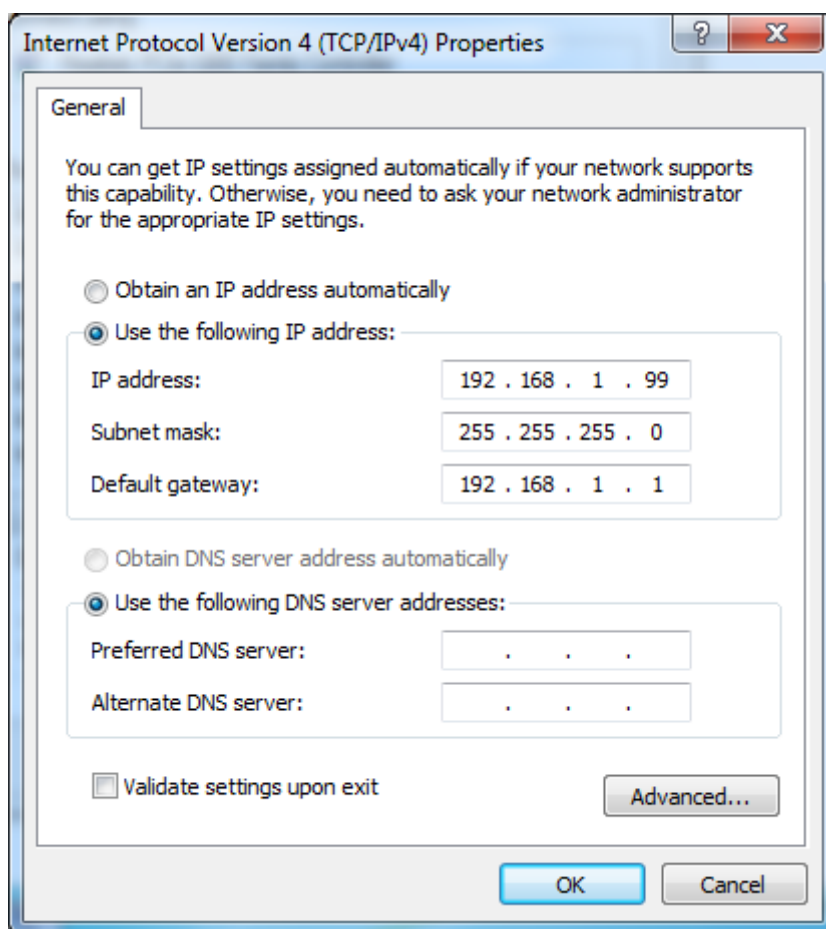

Figure 3-1-2 Set network parameter of computer

Select “Use the following IP address”, fill the IP address 192.168.199 (or the other IP address which is not conflict with 192.168.100 in the same network section); the subnet mask is 255.255.255.0, and defaulted gateway is 192.168.1.1. The others are not required to set; click “Confirm” on this page and the “confirm: on the page of “Local connection property”. Wait for the configuration of the system.

## 3.2 Access through IE browser

**Notice:** When the image of the IP Camera is previewed through the IE browser, it is required to set the safety grade of the browser, thereby facilitating the installation of the plug-in unit. Open the IE browser, enter the menu [Tool/Internet Option/Safety/Self-Definition Grade...]; change “Active control and plug”, “download: in the set to be use or prompt; set the safety grade as “Safety grade-low”, show as Figure 3-2-1.

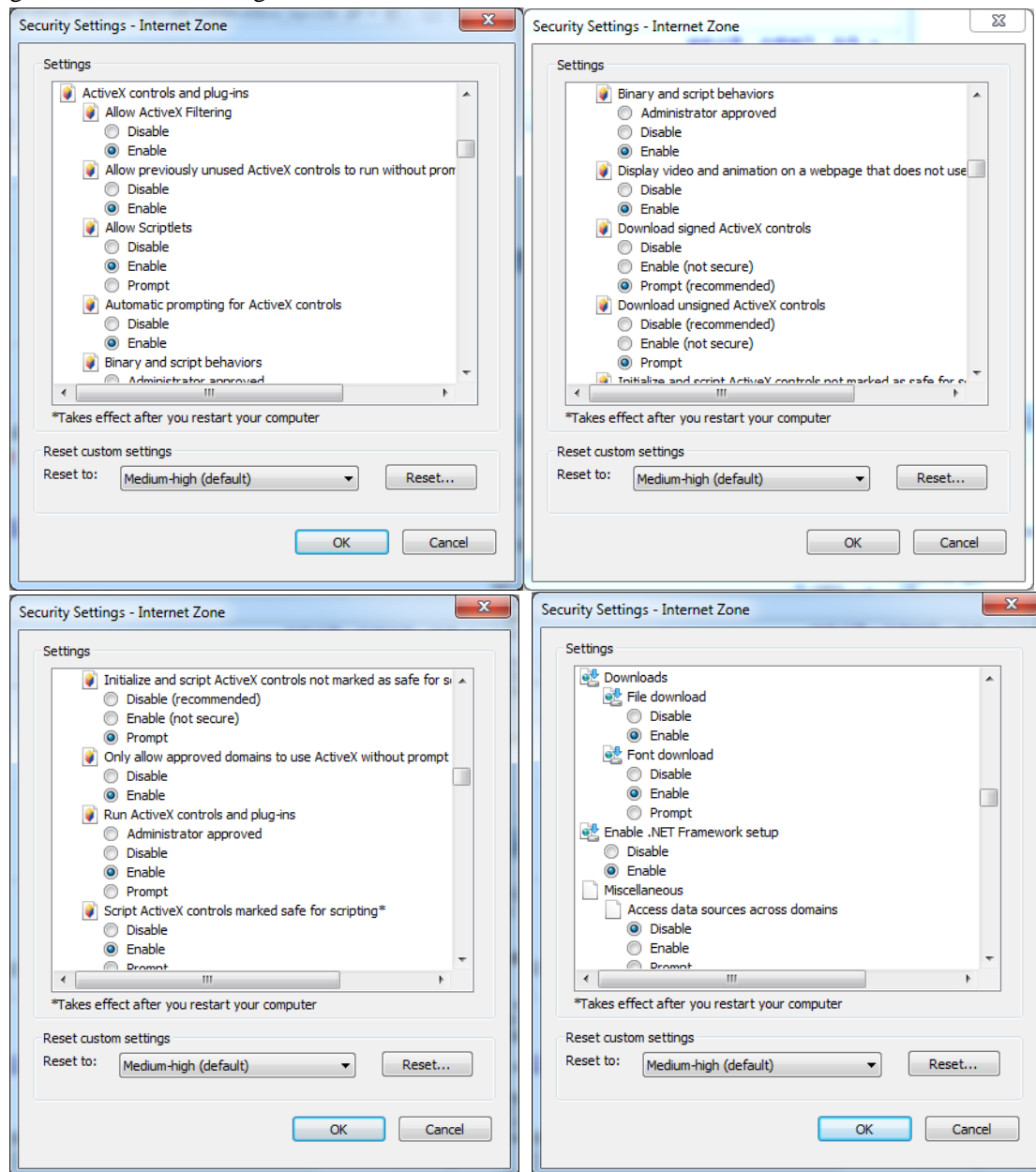

Figure 3-2-1 Safety grade set of IE

### 3.2.1 Preview image

Step I: Install plug-in unit

Input IP address of camera in the IE address bar, and then press Enter in the keyboard, pop up a

prompt of installing Active X plug-in unit as Figure 3-2-2; click the prompt once and select [OK] to select the download plug-in unit; after downloading the plug-in unit, run and install as the dialog box of the installation of Active X plug-in unit in Figure 3-2-3; click [Next] and install the plug-in unit.

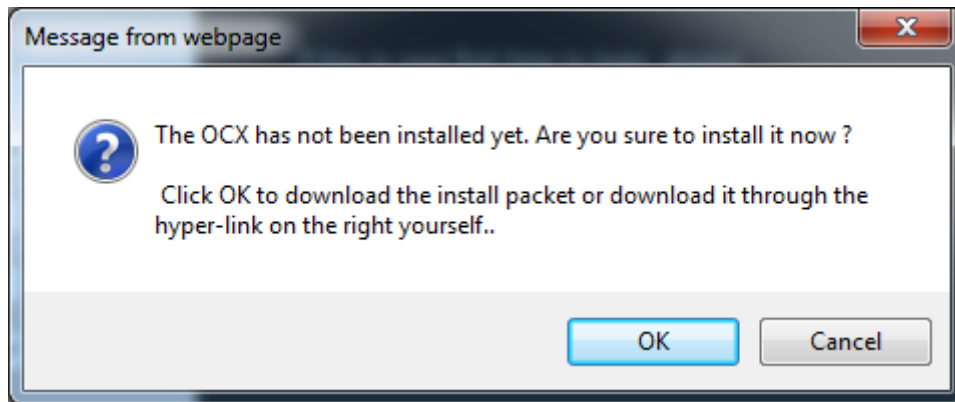

Figure 3-2-2 Prompt of installation of Active X plug-in unit

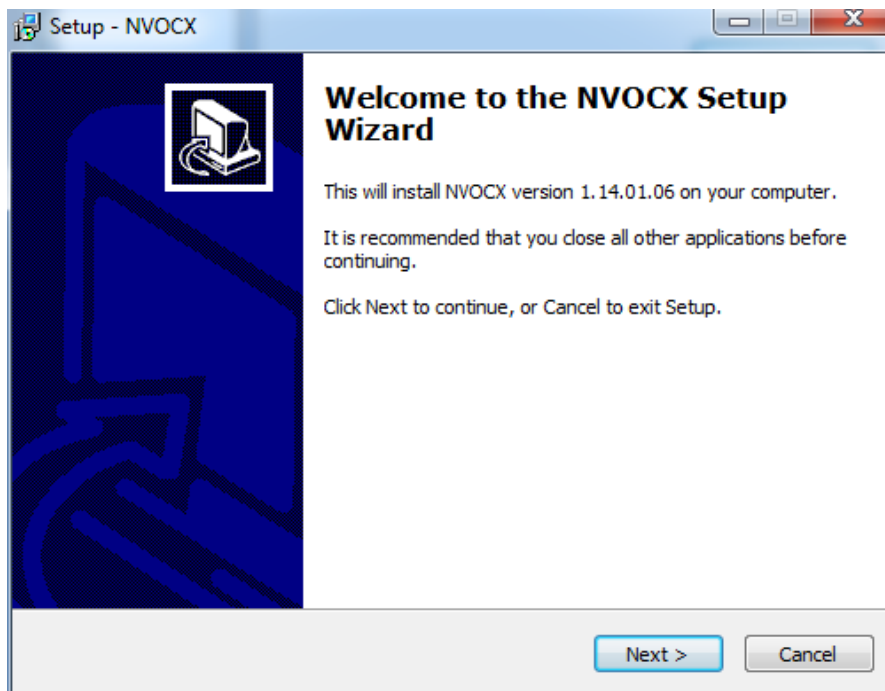

Figure 3-2-3 Installation of Active X plug-in unit

### Step II: Login and preview

Refresh the login interface, input user name (**Default: Admin**), password (**Default: Admin**), port number (**Default: 80**) of the IP Camera on the IE interface, show it as Figure 3-2-4; press Enter in the keyboard, and preview the image, and show it as Figure 3-2-5.

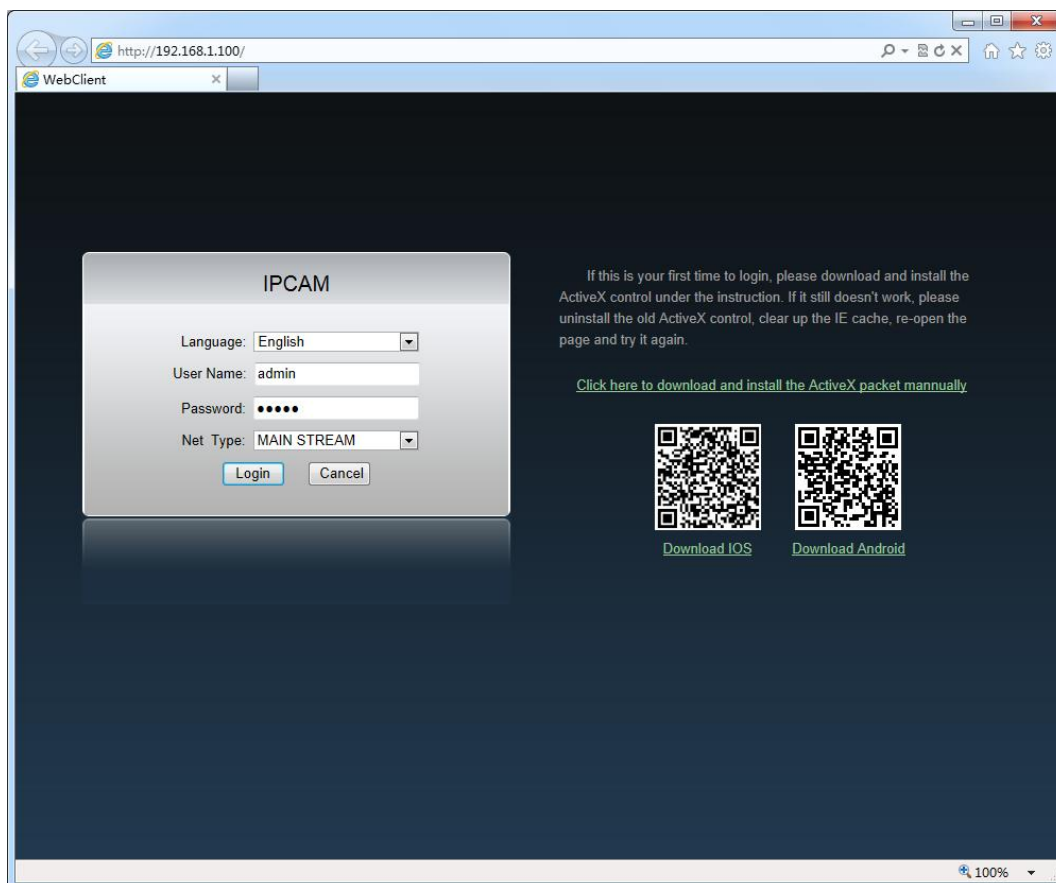

Figure 3-2-4 Login interface

Step IV: click the login button and enter the video previewing interface, show as Figure 3-2-5.

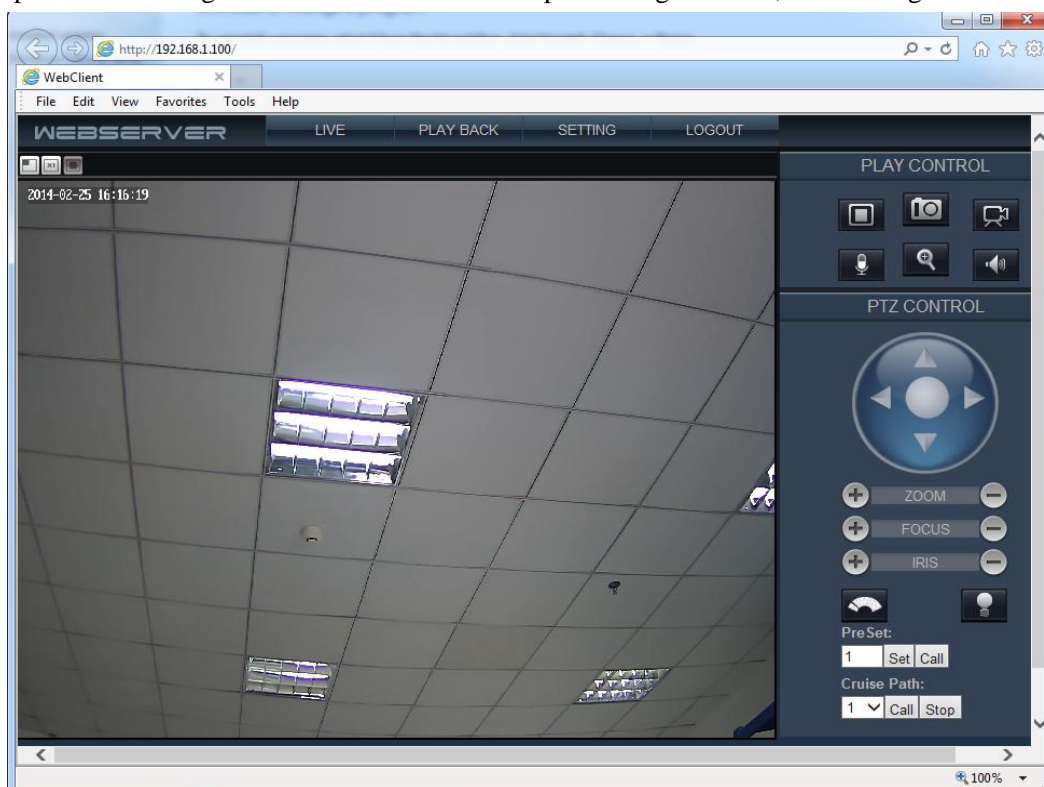

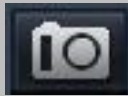

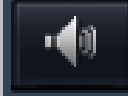

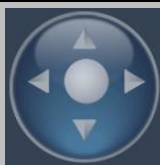

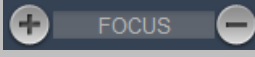
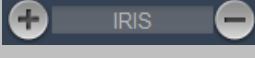



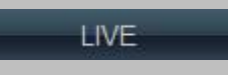
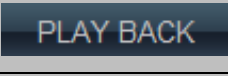

Figure 3-2-5 Preview interface

### 3.2.2 IE preview function

Perform the record, snapshot, talkback, holder, and other operations of the video image on the IE real-time preview page

#### Description of interface function

Icon	Characters	Function description
	Open channel	Click this button, open the channel picture, or close the channel picture
	Snap	Click this button and snapshot the front video
	Record	Click this button and start/stop recording
	Talk	Click the button, start the talkback function with the front IP Camera
	Voice switch	Click this button and switch the turning on and off of the audio
	Wipper	Click the button and start the windshield wiper function
	Light	Click the button and start the lighting function
	PTZ Control	Automatically control all sides of the camera console
	Zoom	Amplify or zoom out the video image
	Focus	Adjust the focal length of lens
	Iris	Adjust size of aperture
	Preset of console	Set and call the preset position of the console

	Real-time preview	Click this menu and switch to real-time preview interface
	Playback	Click the button and switch to the record playback interface
	Set	Click the button and pop up the parameter setting dialog box
	Logout	Click the button and log out

### 3.3 Access through client

#### 3.3.1 Installation of NVClient\_V5 client

Double click the installation program document of the video monitoring management software, and appear the dialog box shown as Figure 3-3-1 below:

Select language to be used in the course of installing: simplified Chinese, English, Russian or Portuguese; click [OK] and click [Next ] according to the prompt until the [Finish] button is appeared; click [Finish] and finish the installation.

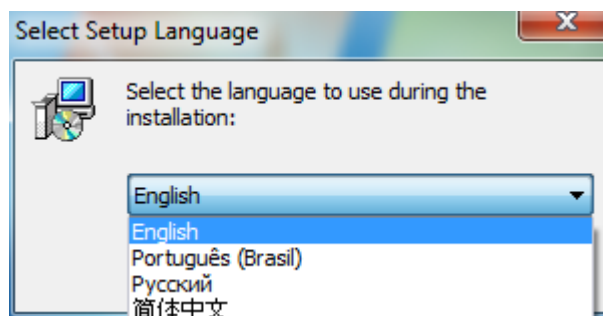

Figure 3-3-1 Language selection for client installation

#### 3.3.2 Client preview image

After installing client NVClient\_V5, click “NVClient” in the menu “Start” ——“Program” ——“NVClient\_V5” of the Windows operation system, run the software, and pop up the user login interface, and then input user name and password (the default user name when the NVClient is used for the first time: admin; the password is empty), click [login] and enter the software interface. **(The detailed operation introduction of NVClient\_V5 shall refer to *Service Manual of Video Monitoring Management Software*)**

Click the [Config] —— [Device] on the menu bar, pop up the dialog box of the equipment management



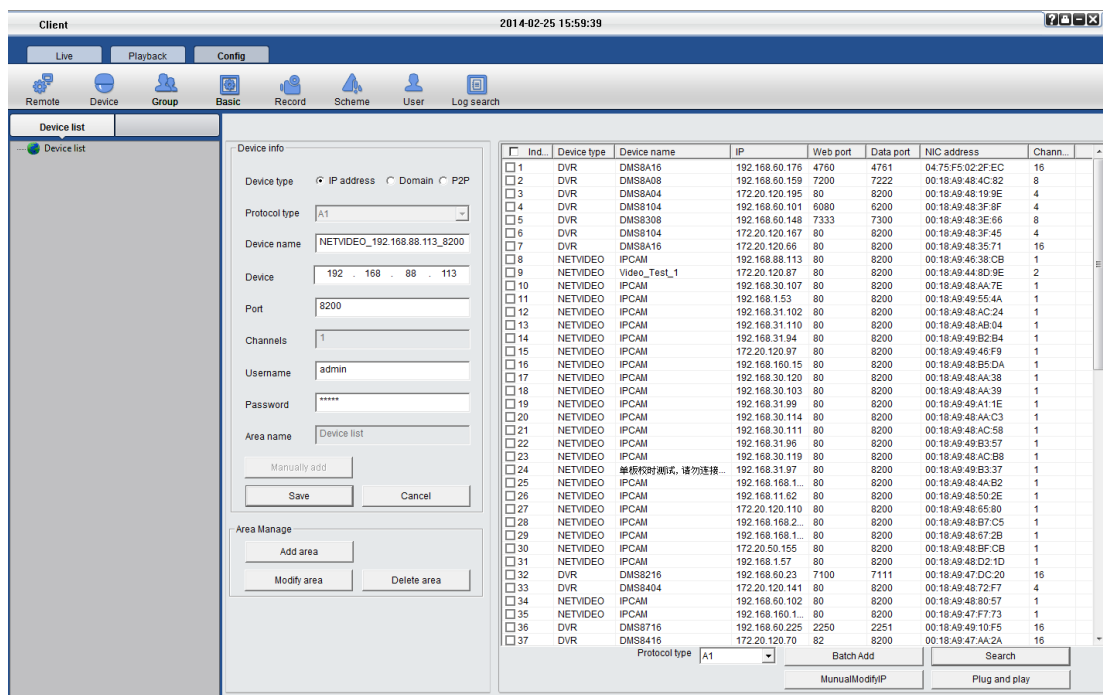

Figure 3-3-2 Equipment administration interface

**The IP Camera adding method in the local LAN is as follows:**

**Method I:**

Search adding:

Click [Search] button of [Device]

Step I: select equipment list node, and then select the equipment to be added from the search list, show as Figure 3-3-3; input the self-defined Device name, user name and password of user.

Step II: click [Save] button on the [Device], add pointed equipment to the pointed equipment zone (click the equipment in the search list twice and directly add the equipment to the pointed equipment zone, wherein the added equipment user name and password clicked twice are admin)

**Method II:**

Manually add:

Step I: select the equipment list node, click [Manually Add] once, show as Figure 3-3-3, and input the self-defined device name, device, port, channels, username and password of user.

Step II: click [Save] button on the [Device], add pointed equipment to the pointed equipment zone

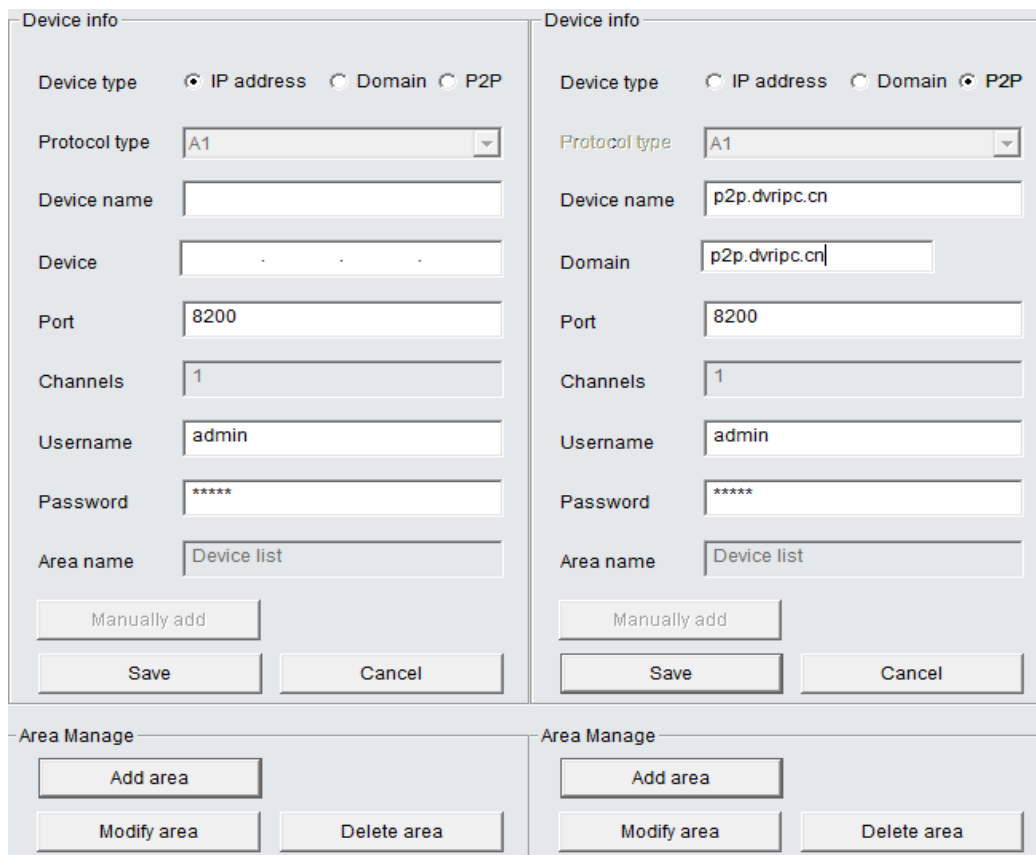

Figure 3-3-3 Add equipment by LAN

Figure 3-3-4 Add equipment by WAN

After adding equipment through method I or method II, return the software real-time preview interface, and double click the channel under the equipment in the equipment list, and then preview the video, show as Figure 3-3-5.

**The adding method of IP Camera of WAN is as follows:**

For the client software is only able to automatically search the network equipment in the local LAN, it is required to manually add IP Camera when user is required to intensively manage the Setting equipment,

The manual adding method of IP Camera includes the following steps:

Step I: select the equipment list node, click [Manually Add] once, show as Figure 3-3-4; input the Setting address (Fill IP address or domain name) of the equipment in the address bar; input user defined local name port number, channel number, user name, and password in the port, (The port number of equipment is defaulted as **8200**, the port can be customized and modified according to the data port in the network set; please check **Chapter 4.4 Network Setting for details**)

Step II: click [Save] button on the [Device], and add the pointed equipment to the pointed equipment zone

After adding equipment, return the software real-time preview interface, click the channel under the equipment twice in the equipment list, and then preview the video as Figure 3-3-5.

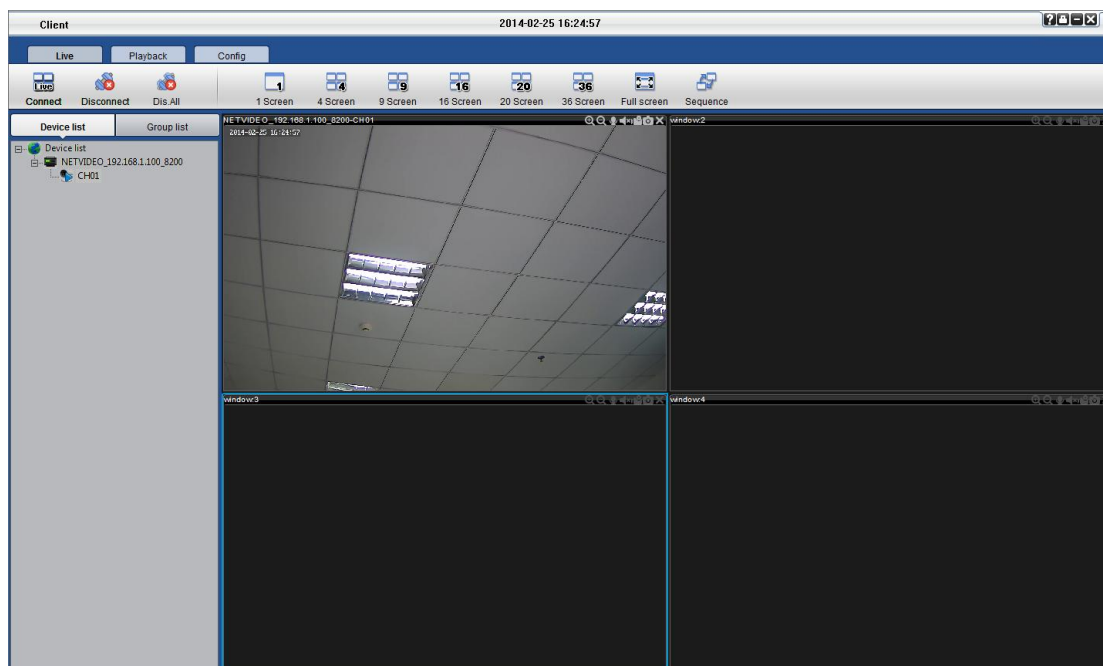

Figure 3-3-5 Client previewing interface in real time

## 4 IP Camera Parameter Setting

There are three methods to enter the IP Camera Setting parameter setting interface, the specific operation is as follows:

**Method I:** Access IP Camera through IE; after logging, click [SETTING] on the preview page and then enter the parameter setting interface of the IP Camera.

**Method II:** Add IP Camera through the video monitoring management software (CMS); after selecting the equipment, click the [Setting] on the software menu and enter the parameter setting interface of the IP Camera.

**Method III:** Add IP Camera through the video monitoring management software (CMS); select the equipment through the right button, click the [Setting] on the right button menu, and enter the parameter setting interface of the IP Camera.

### 4.1 Local Setup

Open [Setting] → [Local Setup]: set the storage path of local record and snapshot, network cache, image display method, and other parameter, show as Figure 4-1-1.

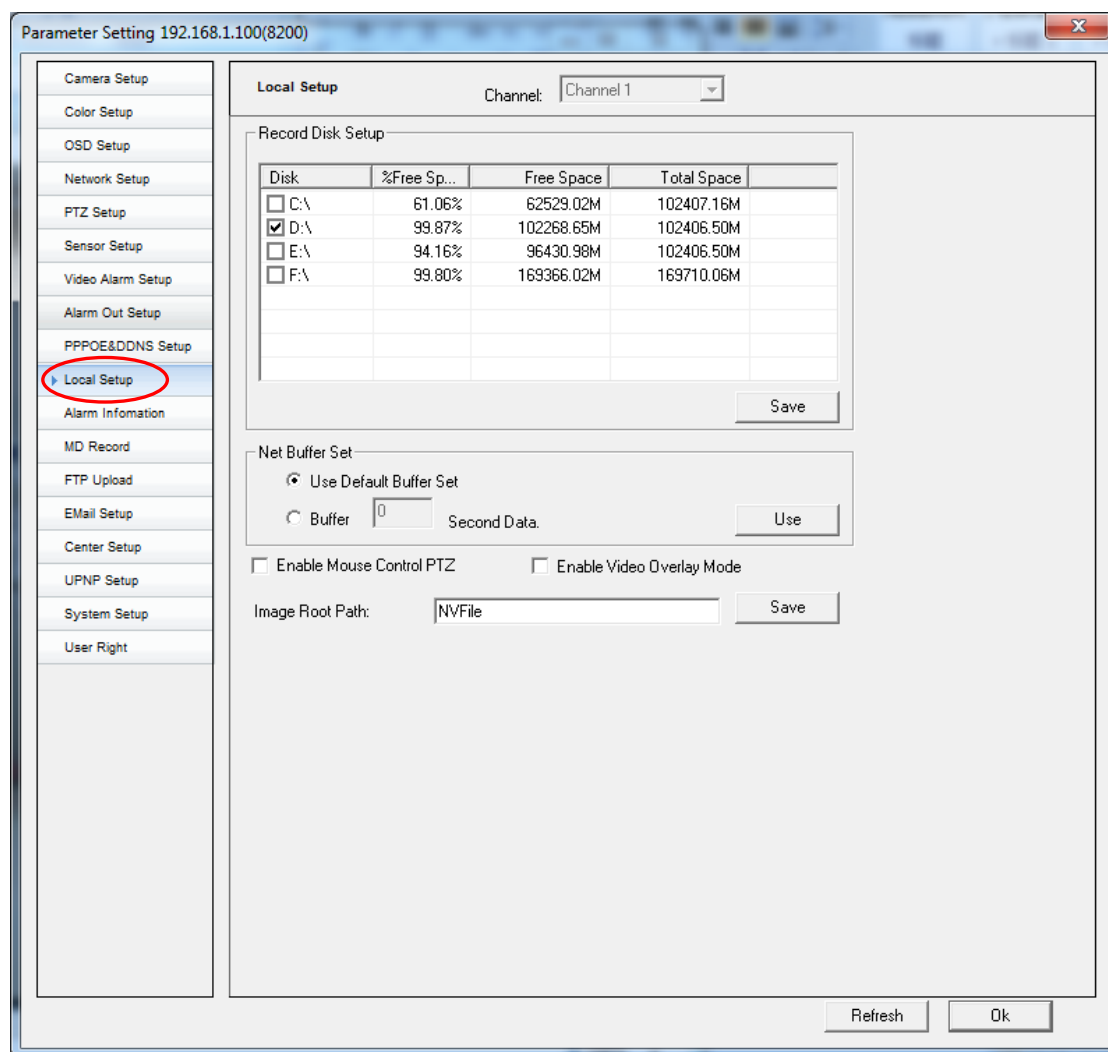

Figure 4-1-1 Local setting

### Description of detailed parameter configuration:

**[Record Disk Setup]** Check the drive of the record to be stored from the magnetic disk list. It is defaulted as system disk D;

**[Net Buffer Set]** When the internet speed of the Setting access is relatively slow, the degree of smooth of the image can be improved through setting the network buffer.

**[Enable Mouse Control PTZ]** After using the function, the holder control can be driven by the mouse directly on the preview video image.

**[Enable Video Overlay Mode]** When the computer configuration is low and cannot display the image, the option can be eliminated to reach the purpose of displaying image, but the image displaying effect can be reduced.

**[Image Root Path]** set the name of the image record storage root catalog as NVFile.

The storage path of the record document is defaulted as D:\NVFile\REAL, the preview screenshot storage path is defaulted as D:\NVFile\Capture.

## 4.2 Network Setup

### 4.2.1 IP Fixed IP

Open [Setting] → [Network Setup]: set “IP Address”, “Mask”, “Gateway”, “DNS Server”, “Media Port”, “Web Port”, and “RTSP Port” of the IP Camera according to the actual demand; set the method of automatically obtaining the IP address.



Notice:

1. When the IP address is set, prevent the IP address from conflicting with the IP address of the other equipment of the LAN; the conflict of the IP address will cause that the equipment cannot login normally
2. After modifying the network parameter, click [Save]-[OK] to modify; thus the IP Camera can automatically store and restart.

By selecting  DHCP  Yes  No (Use the following IP address), you can distribute one legal IP address manually on the IP address bar as Figure 4-2-1

[IP address] The IP address must be the only one and cannot conflict with the other any host or work station on the same one network section.

[Mask] is applied to classify the subnet section.

[Gateway] When the IP Camera is accessed by spanning the net section, the address is required to set.

[DNS] Analyze the server IP address of the dynamic IP address and set a correct DNS address after starting the DDNS function.

[Media port] The audio/video media port of IP Camera, wherein the port scope is 1025-66535, the defaulted value is 8200.

[Web port] The default value of the service port accessed by IP Camera WEB is 80; if the setting is changed, it is required to input http:// IP address:Web port in the course of logging again.

[RTSP port] The default value of the RTSP port of the IP camera is 554, the RTSP port is applied to the video transmission of the RTSP protocol.

[Save] When the setting corresponding to the button is finished, the setting can be finished by clicking the button.

**Do remember: after clicking [Save]-[OK], IP camera will automatically store and restart.**

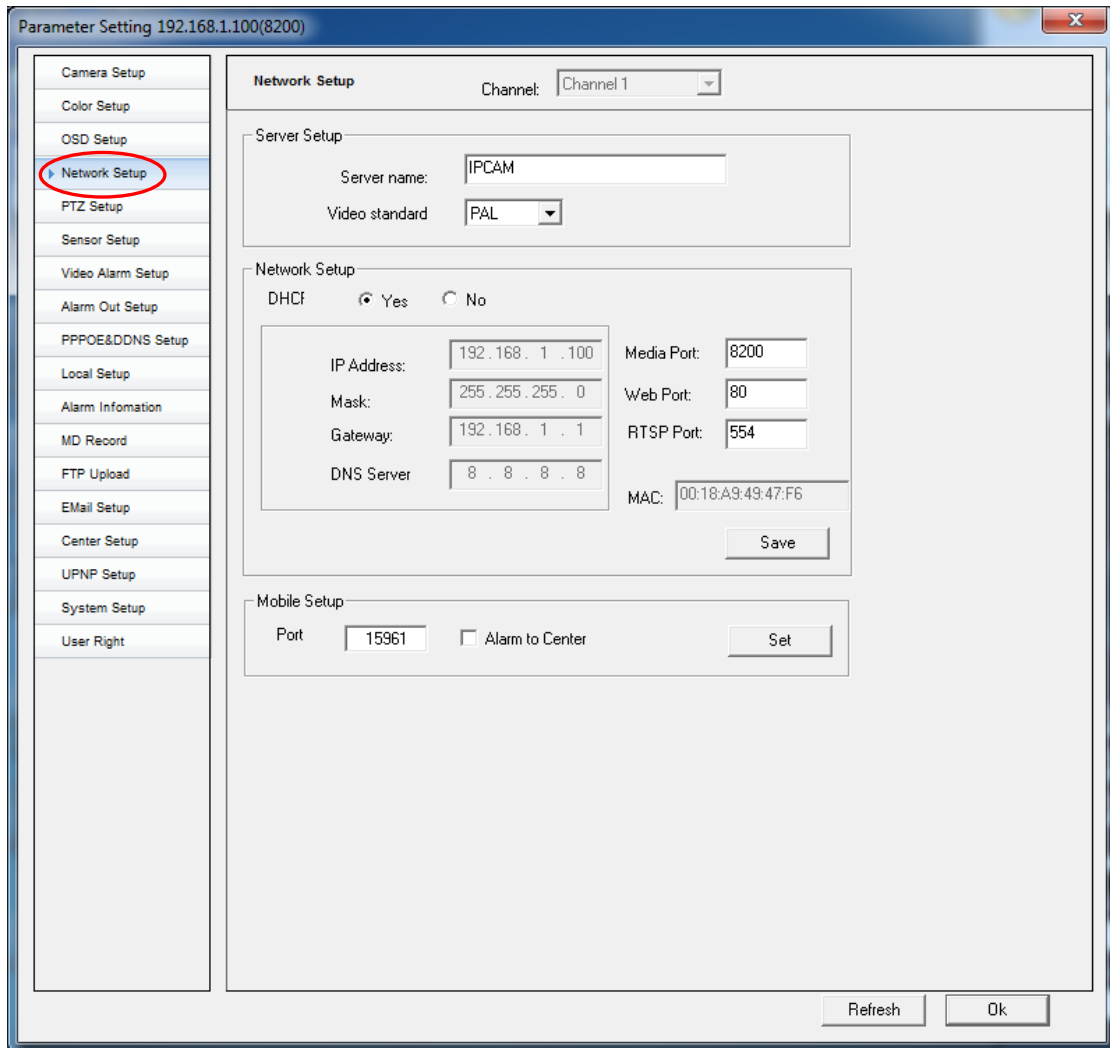

Figure 4-2-1 Network setting

## 4.2.2 DHCP obtaining IP

Open [Seting] → [Network Setup], select  Yes  No (Automatically obtain an IP address), click [Save]- [OK] to modify; the IP Camera will automatically store and restart; after restarting, the equipment can obtain “IP address”, “Mask”, and “Gateway” through the DHCP server; the IP address can be checked through the search tool or the DHCP server.

## 4.2.3 PPPOE dialing

### PPPoE configuration process

**Step I:** Open [Seting] → [PPPOE&DDNS Setup] as Figure 4-2-2

**Step II:** Fill PPPoE [UserName] and [Password] (obtained from the network server)

**Step III:** Click [Save] once, store the parameter setting so that the equipment can login the WAN through dialing directly.

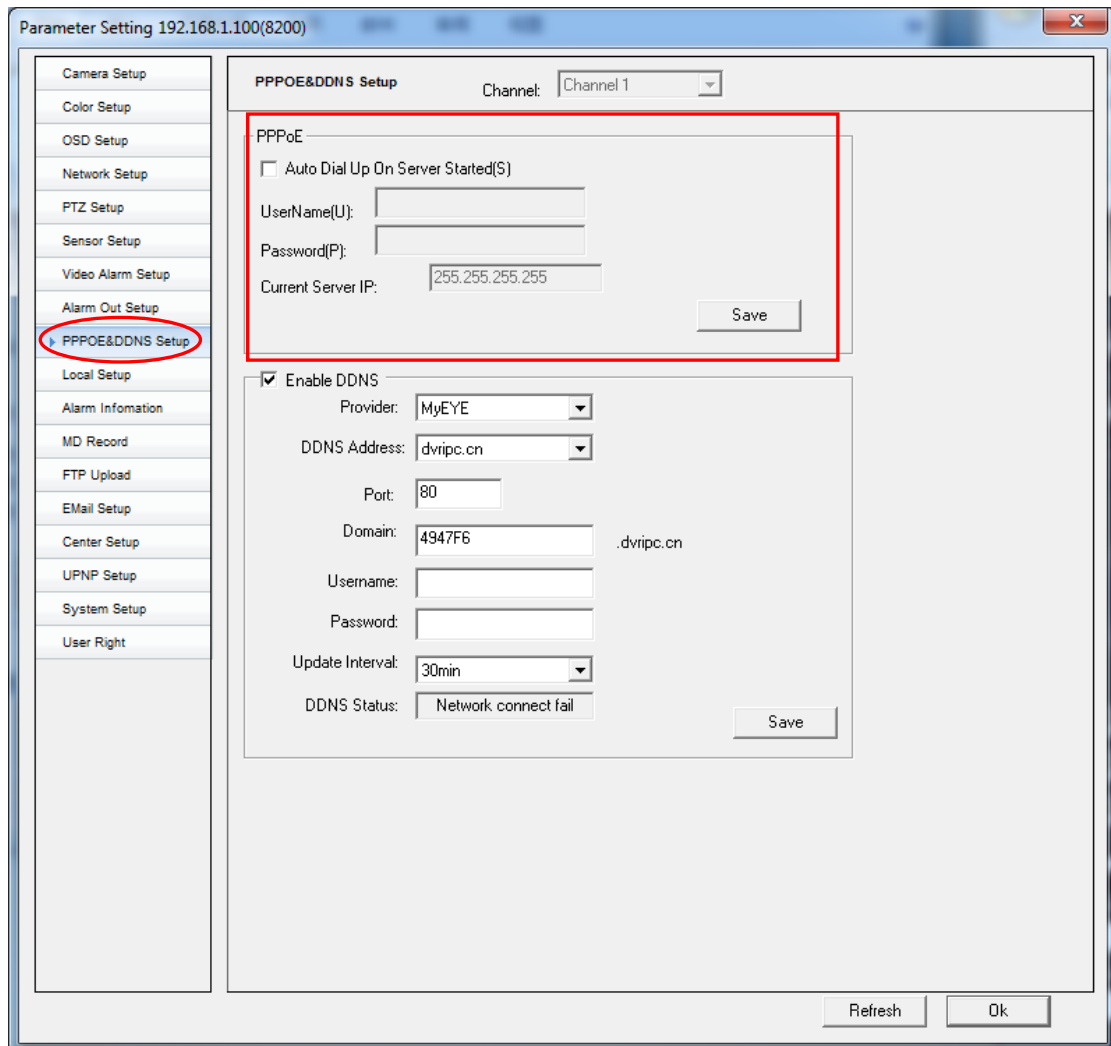

Figure 4-2-2 PPPOE dialing setting

### 4.2.4 Access of center platform

When user uses the platform access, it is required to access the parameter setting of the center platform through the front equipment.

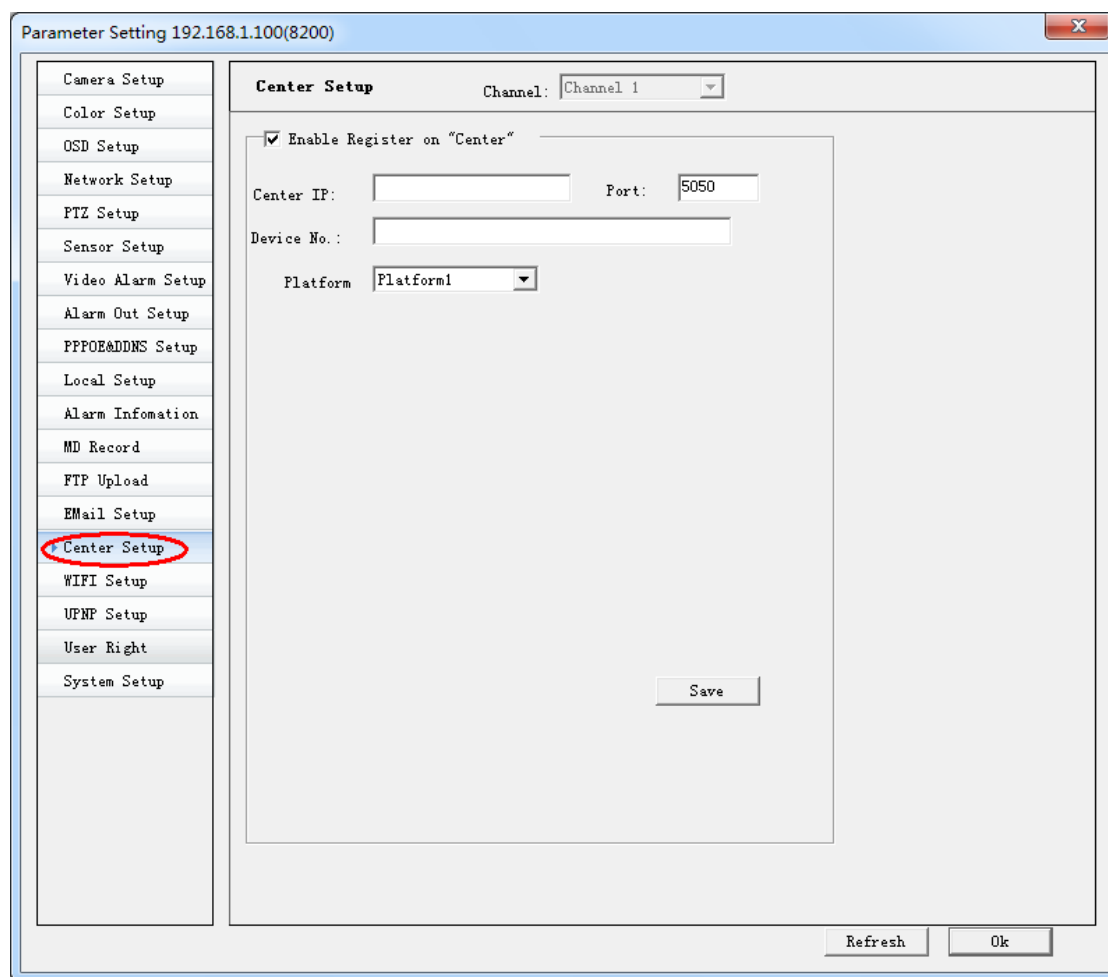

Figure 4-2-3 Access of center platform

## 4.2.5 UPNP

After opening UPNP function, make you IP Camera achieve plug and play by cooperating with DDNS. The “UPNP setting” mainly includes: **[Enable UPNP]**, **[Mode]**, **[Net adapter type]**, **[Local data port]**, **[Seting data port]**, And other settings as shown in Figure 04-2-4:



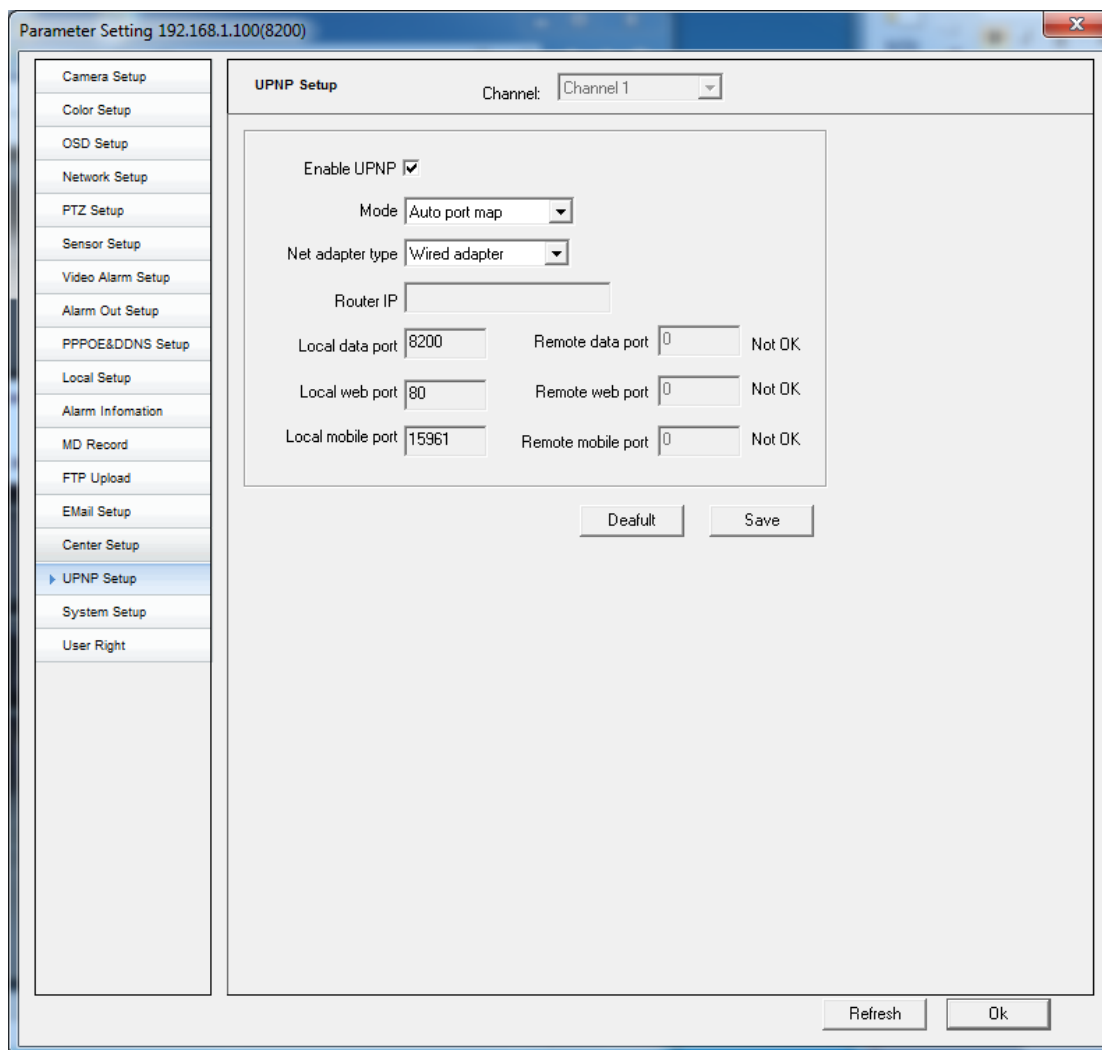

Figure 4-2-4 UPNP settings

**[Enable UPNP]** The ex-factory default value of the camera does not use UPNP; when the UPNP function is going to use, choose **[Enable UPNP]**; select **[Mode]** and **[Net adapter type]** as required, and click **[Save]**.

**[Mode]** There are two optional working methods, which are automatic port mapping and manual port mapping; after setting it to be automatic port mapping, the IP Camera can automatically distribute the mapping Setting port through the router; after setting it to be the manual port mapping, it is required to manually set “Setting data port”, “Setting network port” and “Setting mobile phone port”.

**[Net adapter type]** Select wire network card or the wireless network card to achieve the UPNP function.

**[Local data port]** IP Camera local access port is required to set the local port in the network parameter.

**[Setting data port]** Display the port information of the Setting mapping or manually modify the Setting mapping port.

## 4.3 Video Coding Setting

Open [Setting] → [Camera Setup]: the channel setting interface is shown as Figure 4-3-1; in this setting option, configure the channel name, video code, audio parameter, and other options of the IP Camera.

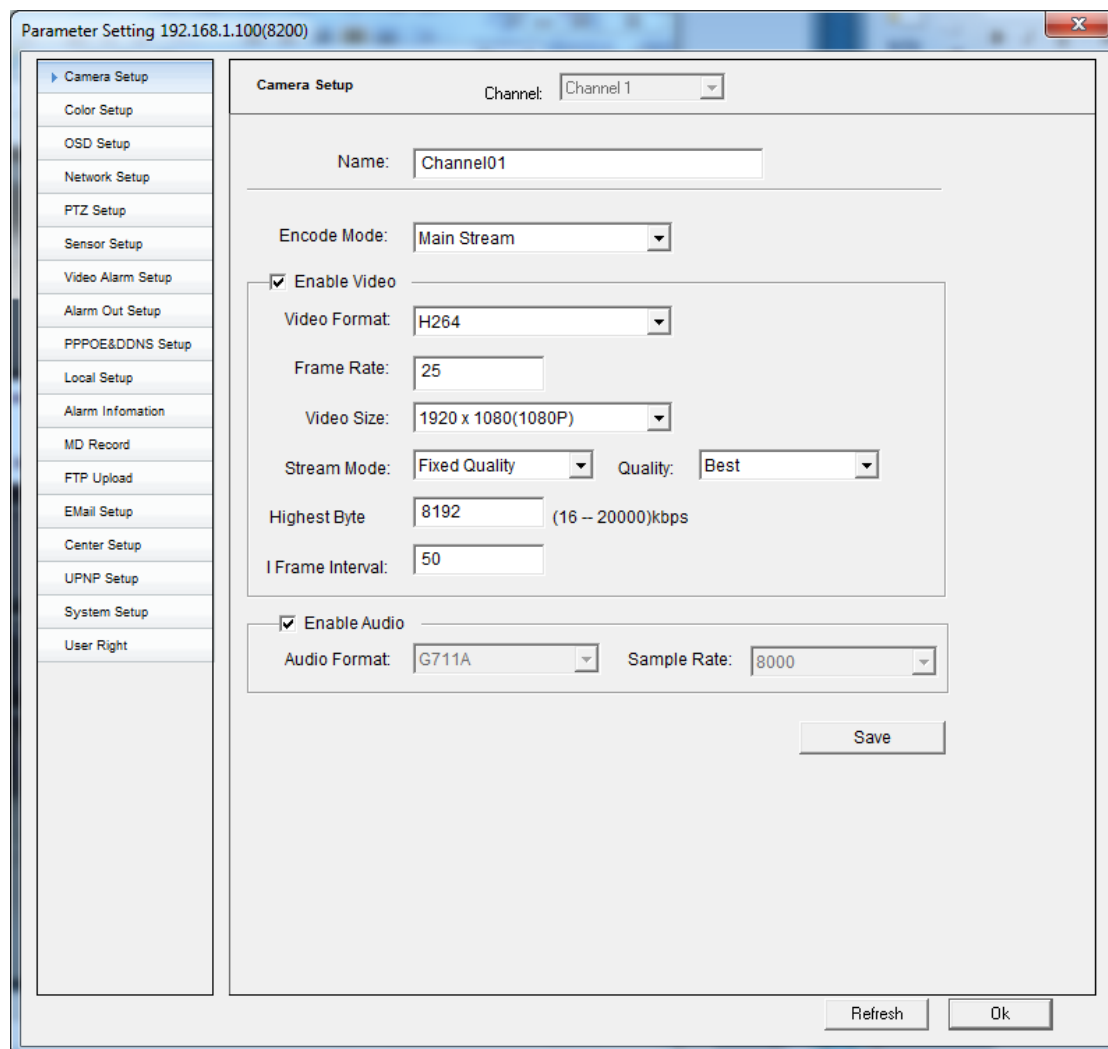

Figure 4-3-1 Channel setting

### Description of option function

[Name] set the channel name of the camera

[Encode Mode] support three code streams, which are respectively: main stream, sub stream, and Mobile

[Video Format] set the coding format, and support H.264

[Frame Rate] set the coding frame rate, which refers to the number of the pictures coded by the IP Camera per second.

[Video size] set the picture size of the coded video of the IP Camera; perform the corresponding setting according to the coding model

[Stream model] constant bit rate and constant quality are optional; when the constant bit rate is selected, the camera can code according to the set fixed code rate; when the constant quality is selected, code is carried out according to the [coding quality] option and the highest code rate

[Quality] five coding qualities can be selected, which are: best, good, normal, not so good, and bad  
 [Highest Byte] the IP Camera is coded according to the constant bit rate  
 [I frame interval], which refers to the number of the P frame or B frame between the key frames (I frames) in the frames (I frame, B frame, P frame) coded by the IP Camera, namely, one key frame is appeared until the number of the coded frame is enough.  
 [Code rate] the code rate refers to the number of the code stream coded by the coder per second, and is represented by bps or bit per second; the scope is continuous and adjustable from 16k to 16000k.

## 4.4 Color Setting

Open [Seting] —→[Color Setup]: the color setting interface is shown as Figure 4-4-1; in this setting item, configure the video Lightness, Contrast , Saturation, Hues, Sharpness, and other options of the IP Camera.

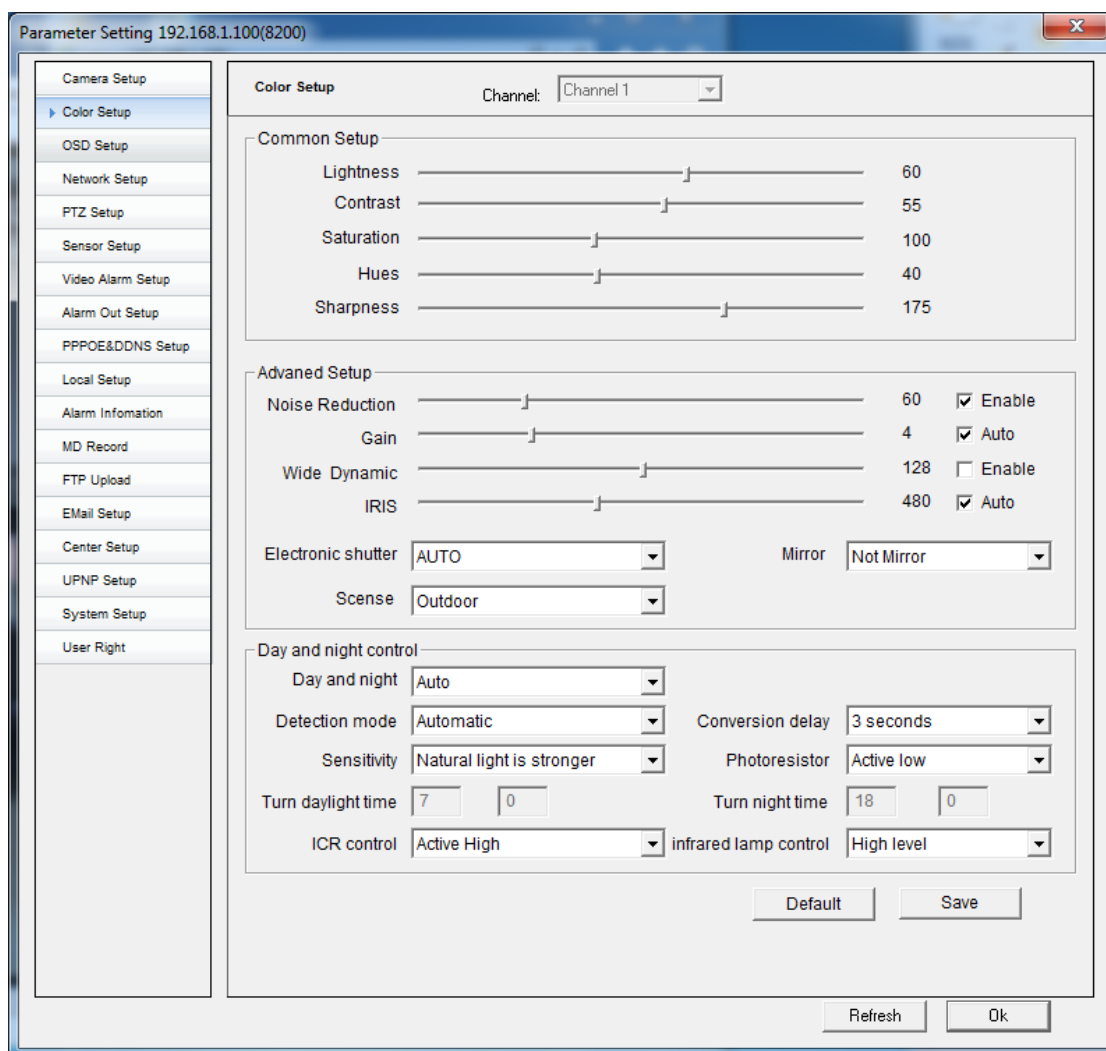

Figure 4-4-1 Color setting

### Introduction of option function

#### Common Setup

[Lightness] adjust the degree of brightness of the picture

[Contrast] adjust the ratio between the brightest and darkest zones of the picture

[Saturation] adjust the bright-colored degree of the color of the picture

[Hues] adjust the tone of the picture

[Sharpness] Adjust the definition of every fine image texture and its border on the picture

### Common Setup

[Noise Reduction] adjust the digital noise value

[Gain] when automatic gain is opened, prompt small signal so that the noise electric level is correspondingly improved.

[Wide dynamic] the bright zone and dark zone, foreground and background of the picture can be saw clearly

[Iris] adjust the amount of light of the lens of the automatic diaphragm

[Electronic shutter] The electronic shutter time is from 1/100s—1/200000s; the electronic shutter of the camera is ordinarily set to be automatic electronic shutter model; the shutter time can be adjusted according to the environmental brightness, thereby obtaining clear picture.

[Scense] the pull-down list has outdoor, indoor, manual and automatic options for choose

[Mirror] the pull-down list has Not Mirror, Top-Bottom, Left-Right and Top-Bottom Left-Right

### Day and night control

[Day and night] Optional auto, black and white, colour

[Detection mode] Optional Automatic, Photoresistor, Video, Time

[Conversion delay] Optional Black and white conversion time can be set from 0 to 10 seconds

[Sensitivity] In the video detection mode, you can set the sensitivity

[Photoresistor] In the photosensitive resistance detection mode can be set Active low or Active high

[ICR control] According to ICR can be set high or low

[infrared lamp control] Can be set to high or low according to the type of infrared light

## 4.5 Character Superimposition and Shade

Open [Seting] → [OSD Setup]: show as Figure 4-5-1. OSD is the abbreviation of On Screen Display; the character superimposition and shade are added in the video image to generate some special characters or figures, thus user can obtain some helpful information. The superimposition character time and content can be displayed in the course of recording and **screen-shooting**. “**✓**” in the **Show Time** **represents that corresponding optional** function is opened; otherwise, the corresponding function is closed.

[Show time]: select formats of different display times according to the actual demand; e.g.

select  and click [Save], display the current time 

of the equipment at the left upper angle in the real-time preview image.

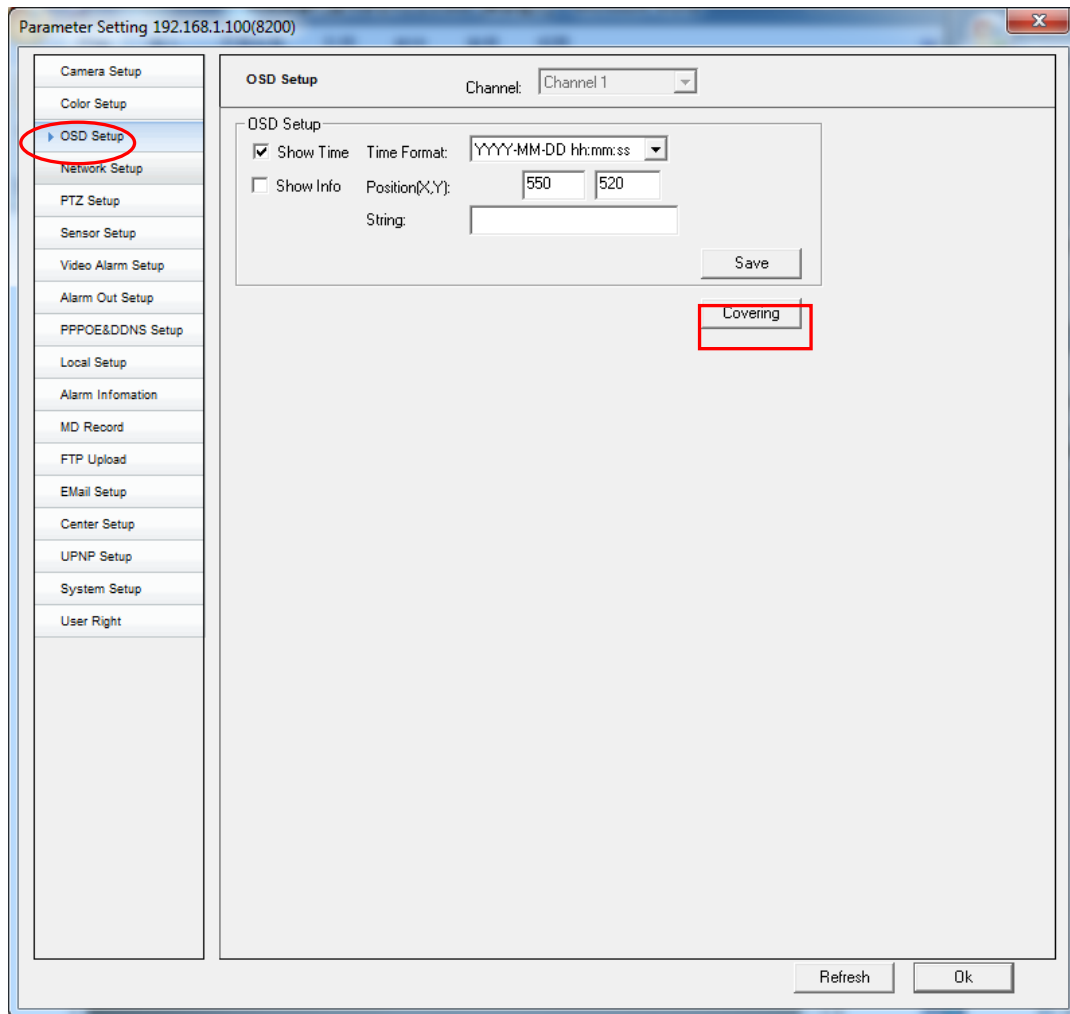

Figure 4-5-1 OSD setting

[Show Info]: input required character in the “described information”, select the display position of the character through “X coordinate” and “Y coordinate” of the described position (X, Y), and then tick the “display description”, namely display the corresponding character in the picture. It is shown as Figure 4-4-1. (The X coordinate value range is 0-cross effective pixel value; Y coordinate value range is 0-longitudinal effective pixel value).

[OSD Setup] → [Covering]: the shade sheeting realizes the function of adding a shade block at the pointed zone, and the setting step is as follows:

**Step I:** click [Covering] once, thus the system will pop up the setting box shown as Figure 4-5-2

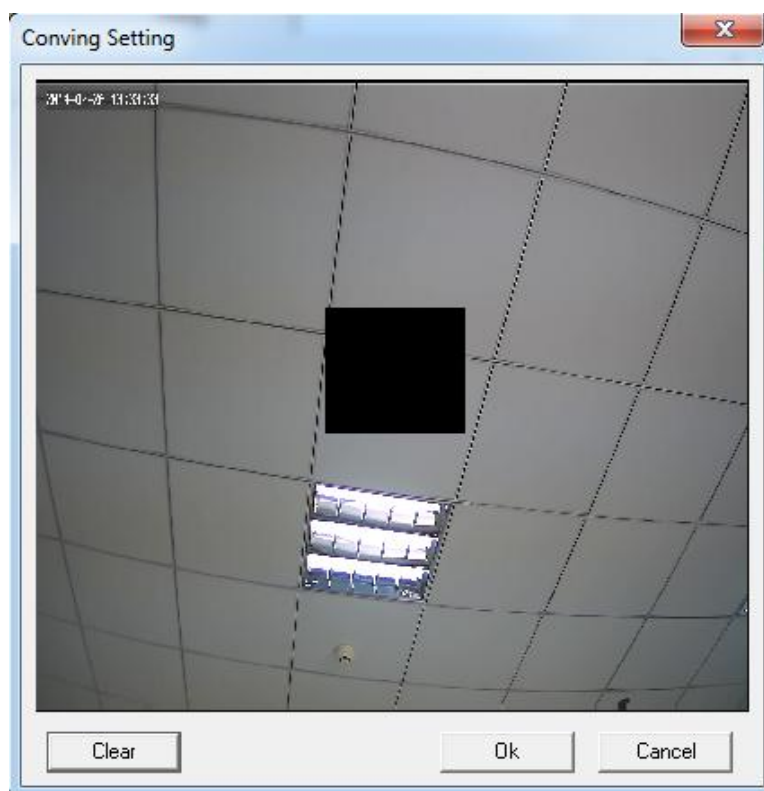

Figure 4-5-2 Shade setting

**Step II:** Drag the left button of the mouse at any position of the picture and draw the zone where you want to shade; remove the shaded zone drawn at present by the right button of the mouse. Five shade zones can be set at most.

**Step III:** click [OK] once, and then display the set shade block in the picture.

If you want to cancel the shade setting, click [Clear] after clicking the “Shade setting” and popping up the setting box; at last, click [OK] once, and then remove shade.

## 4.6PTZ

Open [Seting] →[PTZ Setup]: all IP Cameras of this company support 14 types of common holder protocols; the equipment for connecting the holder is required to set the parameter of the RS 485 interface at this option, such as the PTZ proto, address, Baud rate of the holder.

### Setting steps:

**Step I:** firstly, please correctly set the protocol, address and Baud rate of a ball machine or the holder

**Step II:** correctly connect the 485 communication line of the ball machine or the holder with the IP Camera 485 communication port

**Step III:** select your required protocol from the pull-down menu (matched with the ball machine or the holder); the server supports 13 types of common holder protocols; if the down-pull menu is free from your required protocol, you can upload your own protocol, the server supports transparent transmission, and is defaulted as pelco-d

**Step IV:** set [Address], [Baud rate], [Data], and [Stop bit]; correspond to the front ball machine or the holder

**Step V:** set [Speed], you can freely set the running speed of the ball machine here (0-64 optional)

After confirming the right setting of the holder, click [Save], quit the “Parameter setting” interface, and control the holder through the IE or client

Shown as Figure 4-6-1

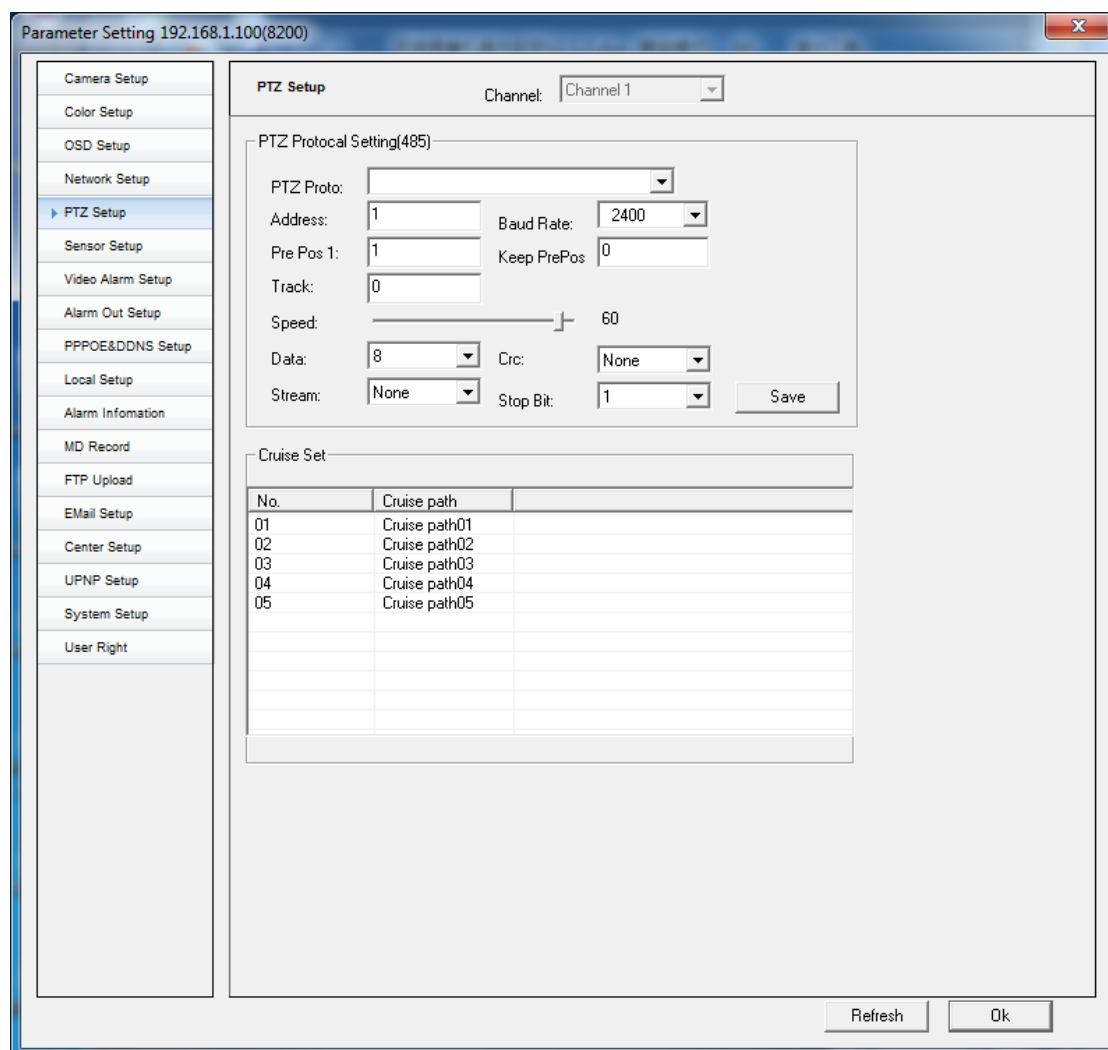
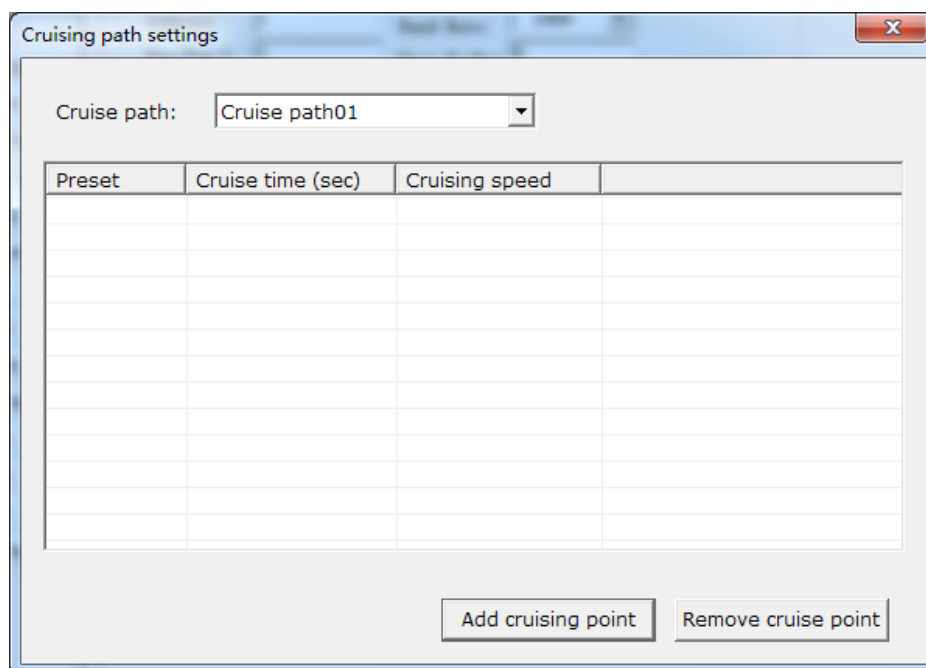

Figure 4-6-1 COM (holder) setting

### Cruise Set

Double-click or right mouse button to enter the cruise path is set, you can add and delete cruise points



## 4.7 Video Mobile Alarm

Open [Setting] → [Video Alarm Setup]

After using the video mobile alarm, when there is movement in the picture under the set zone and the set time, the IP Camera will perform the alarm treatment according to the set action, e.g. linkage snapshot jpg picture, linkage probe output; send the alarm to the client, and then process it by the client according to the local settings.

The video mobile alarm information includes name of server, IP, alarm type, time, and other information, and is stored in the log document for future query. If the client is not connected to the IP Camera during the alarm, the client can be linked through setting to automatically log in the server and open the picture when the alarm happens.

### Set the video mobile alarm



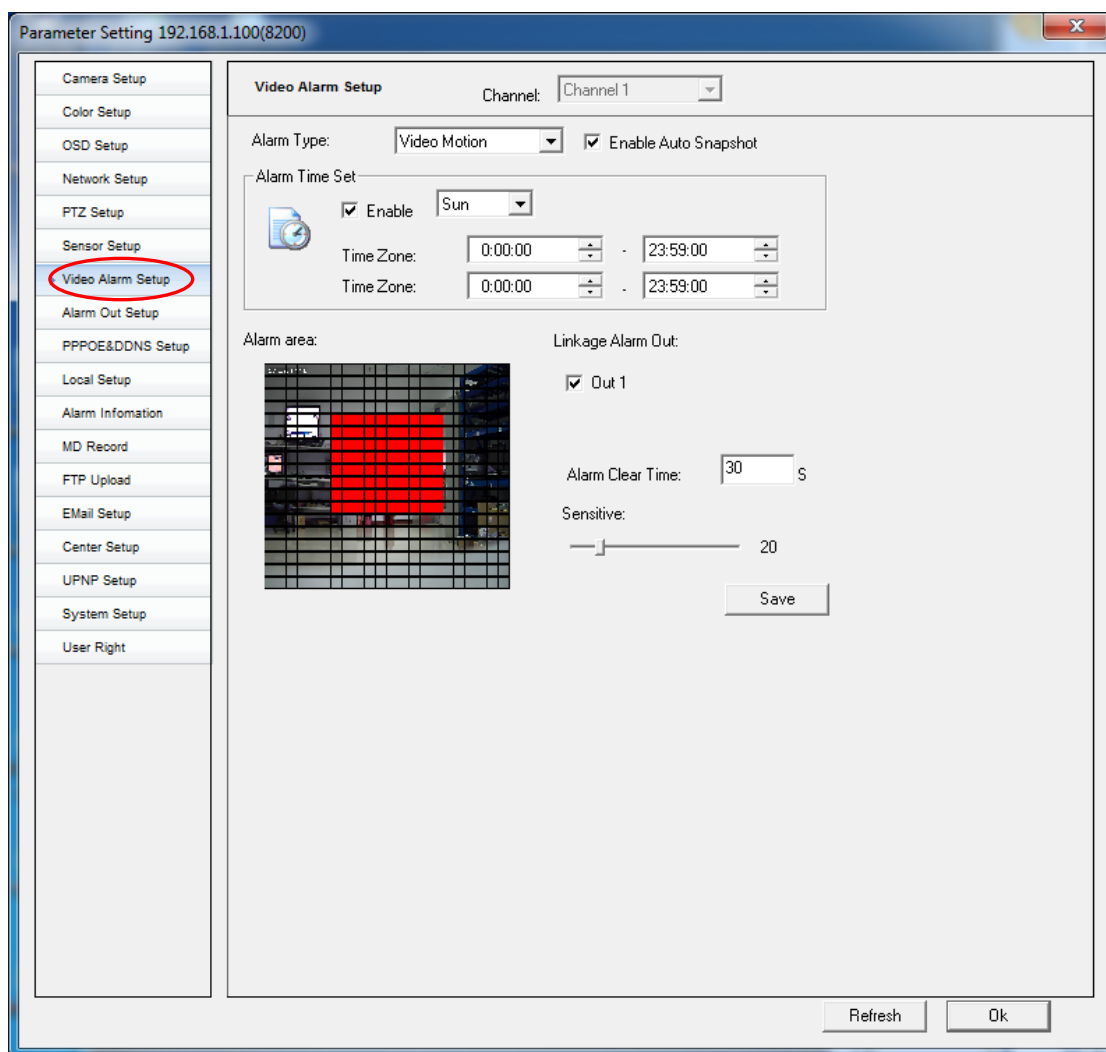

Figure 4-7-1 Video alarm setting

**Setting step is shown as Figure 4-7-1**

**Step I:** select [Video motion] from [Alarm type]

**Step II:** [Enable Auto Snapshot] (optional) tick represents that the alarm linked snapshot is used. Auto snapshot: when the mobile event is happened, the system will store the jpg picture snapshot in alarm to all client machines connected with the IP Camera at present automatically.

**Step III:** set the alarm time section from the [Alarm time set] option, select from Monday to Sunday or every day; tick [Enable] so that the corresponding time alarm setting is used. And then set the deployment time section one and time section two (0:00:00-0:00:00 represents that it is not used during the deployment time section)

**Step IV:** set video [Alarm area]

The picture is partitioned into 18 lines and 22 rows, 396 zones in total can set the dynamic detection; the system out of the set zone will not be detected dynamically; the red display represents that “the zone is picture dynamic detecting zone”; click the right button of the mouse and drag mouse in the picture, and then loose the right button of the mouse, thus the drawing of one zone is finished. Multiple zones can be drawn in the picture.

**Step V:** tick [Linkage alarm out] (optional); the trigger alarm is linkable; alarm output, alarm record, holder preset point, FTP snapshot upload, eMail alarm upload, client talkback request. The

Please check 4.9 Alarm Linkage Setting for alarm linkage setting

**Step VI:** set [Alarm clear time] (1-999 seconds optional)

The alarm eliminating time means that the time of the continuous alarm can automatically eliminate output; namely, the alarm interval time triggered again

**Step VII:** set [Sensitive], wherein the numerical value of the sensitivity is smaller and the sensitivity is higher (5-100 optional)

### Skill of setting

1. In order to avoid the movement of small matters in the picture and cause unnecessary alarm, set the sensitivity to be higher.
2. Set the sensitivity to be higher at the place with relatively frequent movement in case of frequently alarm
3. Set the sensitivity value to be lower if very refined movement alarm is required (except for very sensitive), it is recommended that the value of the sensitivity should be higher in the other cases.

**Step VIII:** after confirming the right setting, click [Save] and quit the “parameter setting” interface

## 4.8 Alarm Input

When the probe alarm is used, the IP Camera can be linked when the probe input alarm happens:

- Link the preset alarm output
- Snapshot the jpg picture and upload to the pointed host
- Automatically dispatch the preset position of the set ball machine.
- Send the alarm information to the client.

**Sensor Setup:**

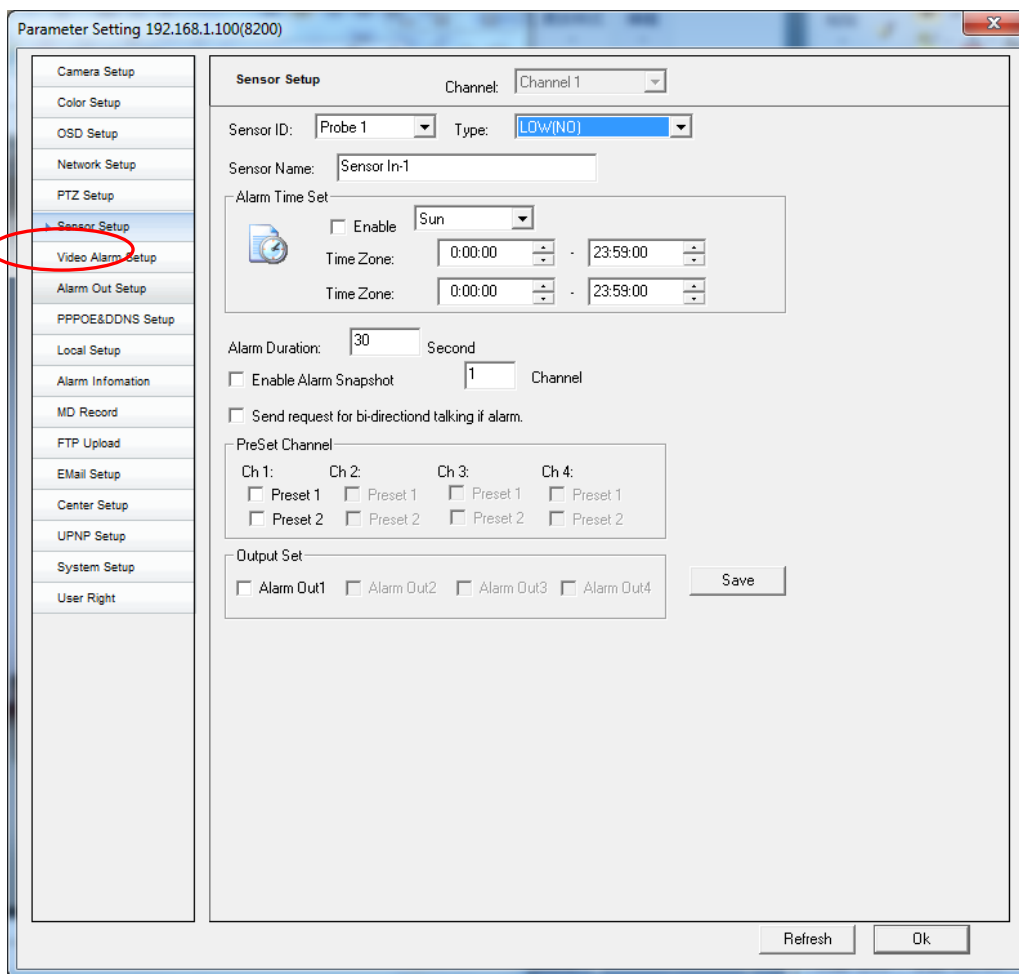

Figure 4-8-1 Probe input alarm setting

**Step I:** hardware connection, correctly connect the alarm input device to the alarm input interface of the IP Camera

**Step II:** open [Seting] → [Sensor Setup], open the probe alarm setting interface as shown in Figure 4-8-1

**Step III:** according to the type of the accessed probe, select [Sensor ID] and [Type], and customize the [Sensor Name]

**Step IV:** [Alarm Time Set], select from Monday to Sunday or everyday; tick [Enable], which represents that the corresponding time alarm setting is used; and then arrange the deployment time section one and time section two (0:00:00-0:00:00 represents that it is not used during the deployment time section)

**Step V:** set [Alarm Duration] (1-1800 seconds optional); the alarm release time means that the alarm lasts to the set time and then automatically eliminates the output, namely the alarm interval time triggered again.

**Step VI:** [Enable Alarm Snapshot] (optional); after ticking use, snapshot the picture of current channel and stored local or linkage output when the probe triggers

**Step VII:** tick [Preset Channel] (optional); when the probe is triggered, adjust the linkage accessed holder to the pointed [Preset1] or [Preset2]



**Note:**

**Externally connect the holder supporting the preset position and set the pre-used preset position under the main interface**

**Step VIII:** tick [Output Set] (optional); user can externally connect with bell, alarm lamp, alarm number, and other alarm equipment; when the probe triggering event happens, the system will link the output switching value to the external device or FTP snapshot uploading, and Mail alarm uploading. As for the detailed setting of the alarm linkage, please check 4.9 Alarm linkage setting

## 4.9 Alarm Linkage

The alarm linkage can set: alarm output, alarm record, alarm information, FTP snapshot and upload, eMail alarm uploading.

### 4.9.1 Alarm output

**Open [Setting] → [Alarm Out Setup], wherein the main function of alarm output is to link and trigger the pointed probe output switching value when the alarm happens so as to trigger the alarm equipment, such as bell. You also can manually control the “On” and “Off” of the alarm output relay, the setting is shown as Figure 4-9-1:**

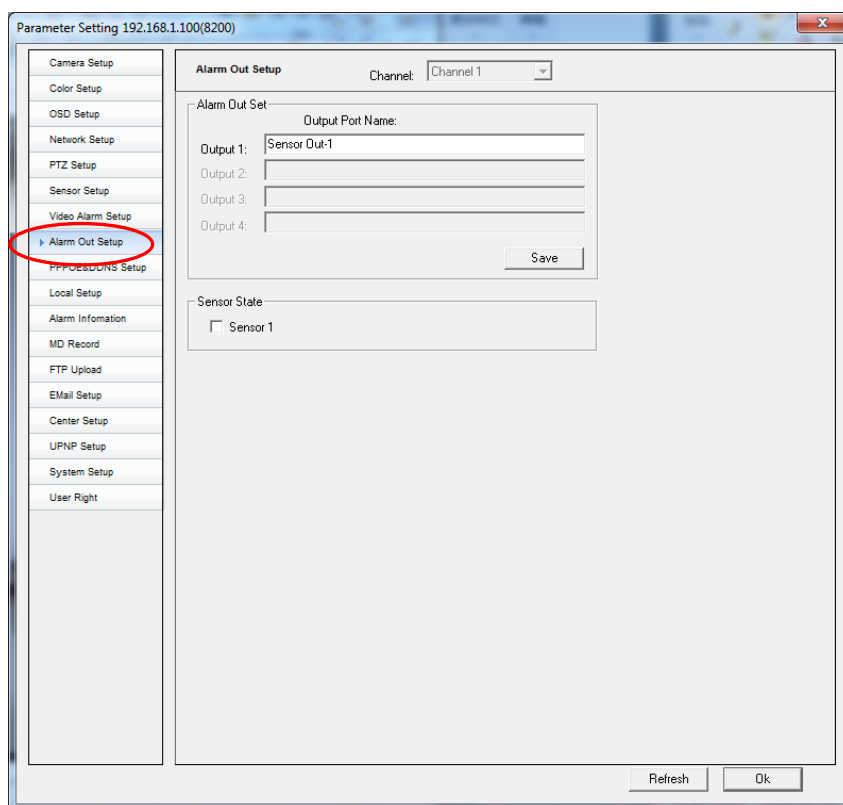

Figure 4-9-1 Alarm output setting

[Output1] select type according to the connected alarm output equipment

[Output Port Name] customize the name of the switch and also can select default

[Save] click this button and store the parameter settings

## 4.9.2 FTP uploading

FTP alarm uploading means that when the alarm happens and it is required to upload pictures to one FTP server on the network, the IP Camera can upload the picture to the pointed FTP server automatically.

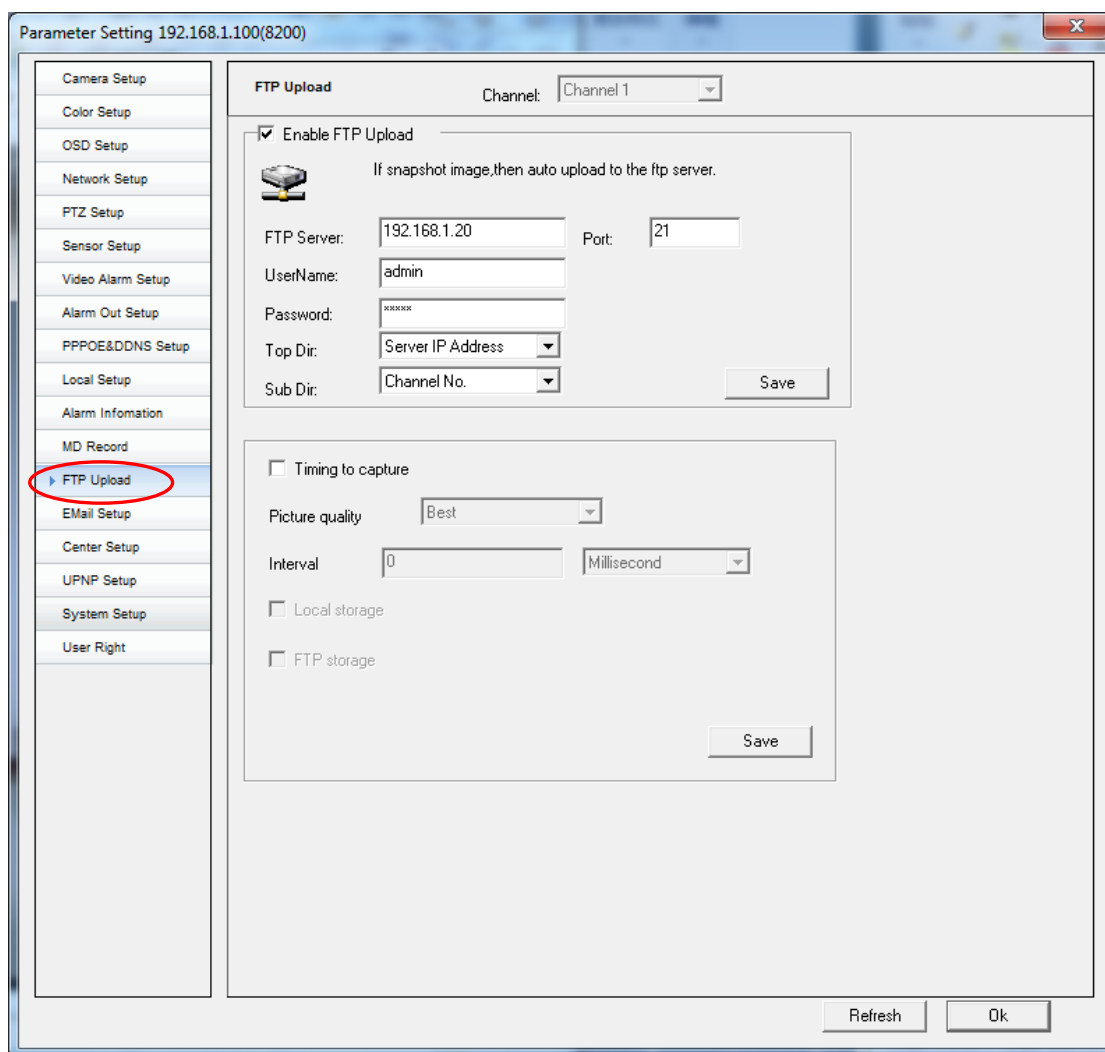

Figure 4-9-2 FTP uploading setting

### Configuration step of FTP

After setting the following options correctly, the FTP uploading function can be realized

**Step I:** install FTP server (please consult the enterprise network administrator for the specific installing method)

**Introduction:** the Serv-U series FTP server software is recommended

**Step II:** open [Seting] → [FTP Upload], show as Figure 4-9-2: tick [Enable FTP Upload], which

represents that the FTP function is used.

**Step III:** according to the settings of the FTP server, fill correct supporting IP address and domain name, [Port], [UserName], and [Password] of the [FTP server]

**Step IV:** set [Top Dir, Sub Dir], which refers to the naming method of the picture file stored on the FTP server; OFF represents that the catalogue is not set up

**Step V:** click [Save] once, quit and store parameter

### Timing to capture

Needed to set up timing to capture, capture interval is set, you can store a local disk and FTP

## 4.9.3 Email alarm uploading

Email alarm uploading means that when the alarm happens and it is required to send pictures to the Email box, IP Camera will automatically send the alarm information and the snapshot pictures to the pointed Email box.

Parameter Setting 192.168.1.100(8200)

Camera Setup  
Color Setup  
OSD Setup  
Network Setup  
PTZ Setup  
Sensor Setup  
Video Alarm Setup  
Alarm Out Setup  
PPPOE&DDNS Setup  
Local Setup  
Alarm Information  
MD Record  
FTP Upload  
**Email Setup**  
Center Setup  
UPNP Setup  
System Setup  
User Right

**Email Setup** Channel: Channel 1

Enable EMail Send Alarm

EMAIL Server: satp.qq.com PORT: 25

Username: myqqemail@qq.com Pass word: \*\*\*\*\*

From: myqqemail@qq.com

To: myqqemail@qq.com

Copy: myqqemail@qq.com BCopy: myqqemail@qq.com

Attach Pic:  Save

Encryption:

Refresh Ok

Figure Email alarm uploading setting

**The Email uploading setting step:**

**Step I:** open [Seting] → [Email Setup] as Figure 4-9-3; tick [Enable Email Send Alarm], which represents that the function is used.

**Step II:** set [Email server] and [Port], wherein the Email server refers to the Email server address used by the mailbox of the sender; the port number refers to the port of the Email server (if the port is unknown, please check it by logging in the official website of the Email server according to the set Email server). At present, it supports smtp.qq.com, smtp.sohu.com, smtp.163.com, smtp.126.com, smtp.sina.com, smtp.hotmail.com, smtp.gmail.com, smtp.yahoo.com, smtp.yeah.net, and other Email servers at home and abroad.

**Step III:** set [Username, Password], and input corresponding user name and password according to the mailbox of the sender.

**Step IV:** set sender, receiver, copy, blind carbon copy, attached picture

[From] refers to the mailbox address used by the sender, and sender must fill it

[To] refers to the mailbox address used by the receiver, and receiver must fill it

[Copy] refers to that the mail you wrote can send to the mailbox wrote at the copy bar except for the receiver, and receiver knows that you have sent the mail to him and the person with the mail address input to the copy bar.

[BCopy] refers to that the mail you wrote will be sent to the mailbox address at the blind carbon copy bar except for the receiver, but the receiver does not know that you have sent the mail to the person with the mail address input to the blind carbon copy bar.

[Attach Pic] this option represents that pictures are automatically snapshot when alarm happens and uploaded through Email, and receiver can check the snapshot pictures through the attachment.

### 4.9.4 Alarm record

The alarm record means that record can be carried out through the client or the mobile magnetic disk when the alarm is triggered. For the client record setting, please check [Using manual of video monitoring management software]; for the mobile disk record setting, please check 4.10.1 Mobile disk recording

### 4.9.5 Alarm information

Open [Seting] → [Alarm Information]; check the probe alarm information, mobile detecting alarm information, abnormal error of mobile disk, and other information in real time.

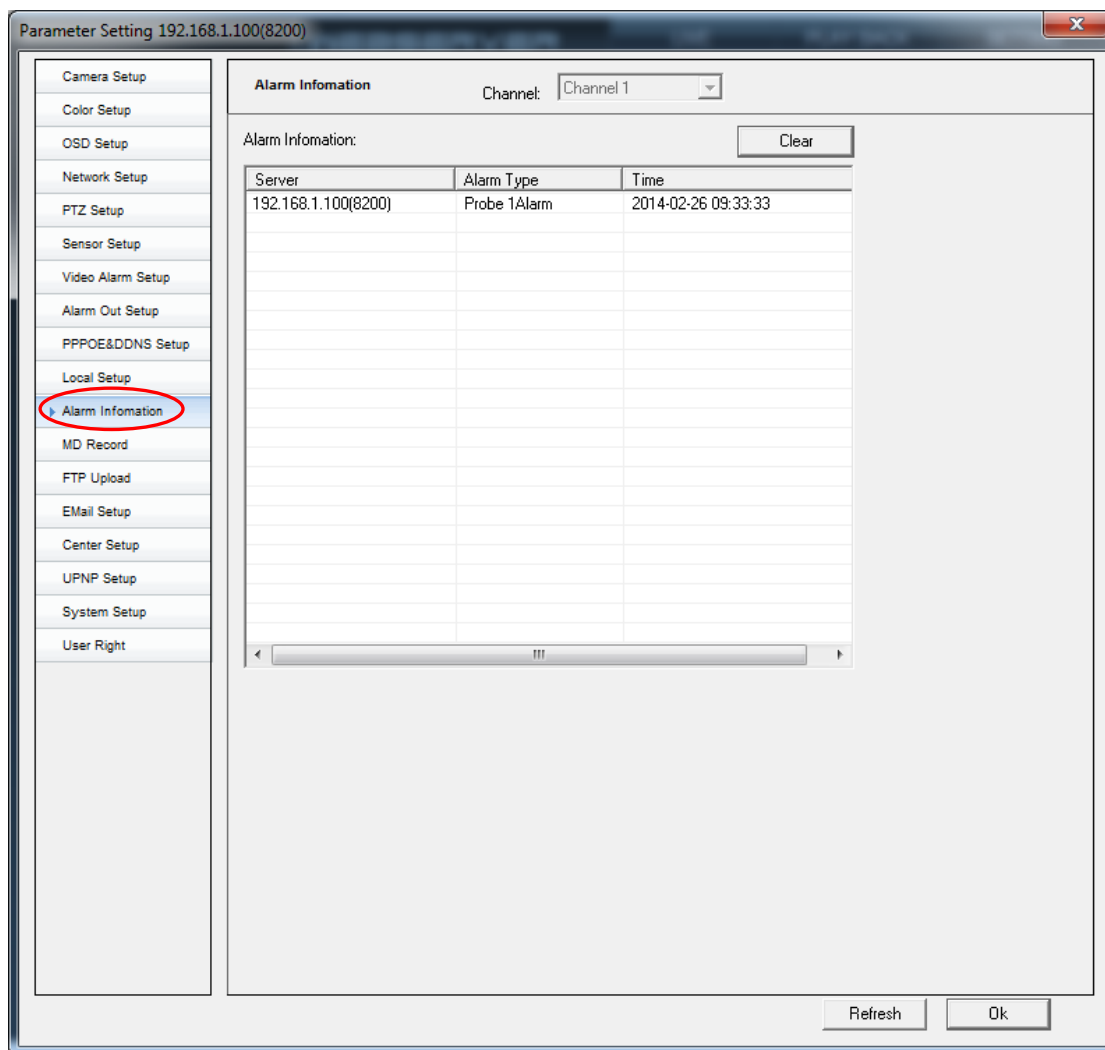

Figure 4-9-5 Alarm information

## 4.10 System Setup

### 4.10.1 Time correction

The time correction has two methods; open [Seting] → [System Setup]:

I. **[NTP Time Sync]**: the system provides automatic NTP time correction; the network of the IP Camera is required to access the public network, please configure the network according to “Chapter 4.2 Network Configuration”. According to the actual demand: tick **[NTP Time Sync]** and use it as Figure 4-10-1, select **[Time Zone]** (capable of setting 24 time zones throughout the world), set NTP server address, NTP port, and time interval. Click **[Set]**, store parameter. The defaulted NTP server address: time.windows.com; port: 123; the time interval is the integer from 1 hour to infinite.

II. **[Manual time correction]**: the system provides the Seting IP Camera and PC time correction function; after confirming that the time of PC is correct, the IP Camera will correct time with the PC by clicking [Set]



**Note:** [Manual time correction] is carried out according to the PC terminal time; therefore, when it is required to the time of IP Camera, time of PC terminal is only required to modify, and then the time correction can be carried out.

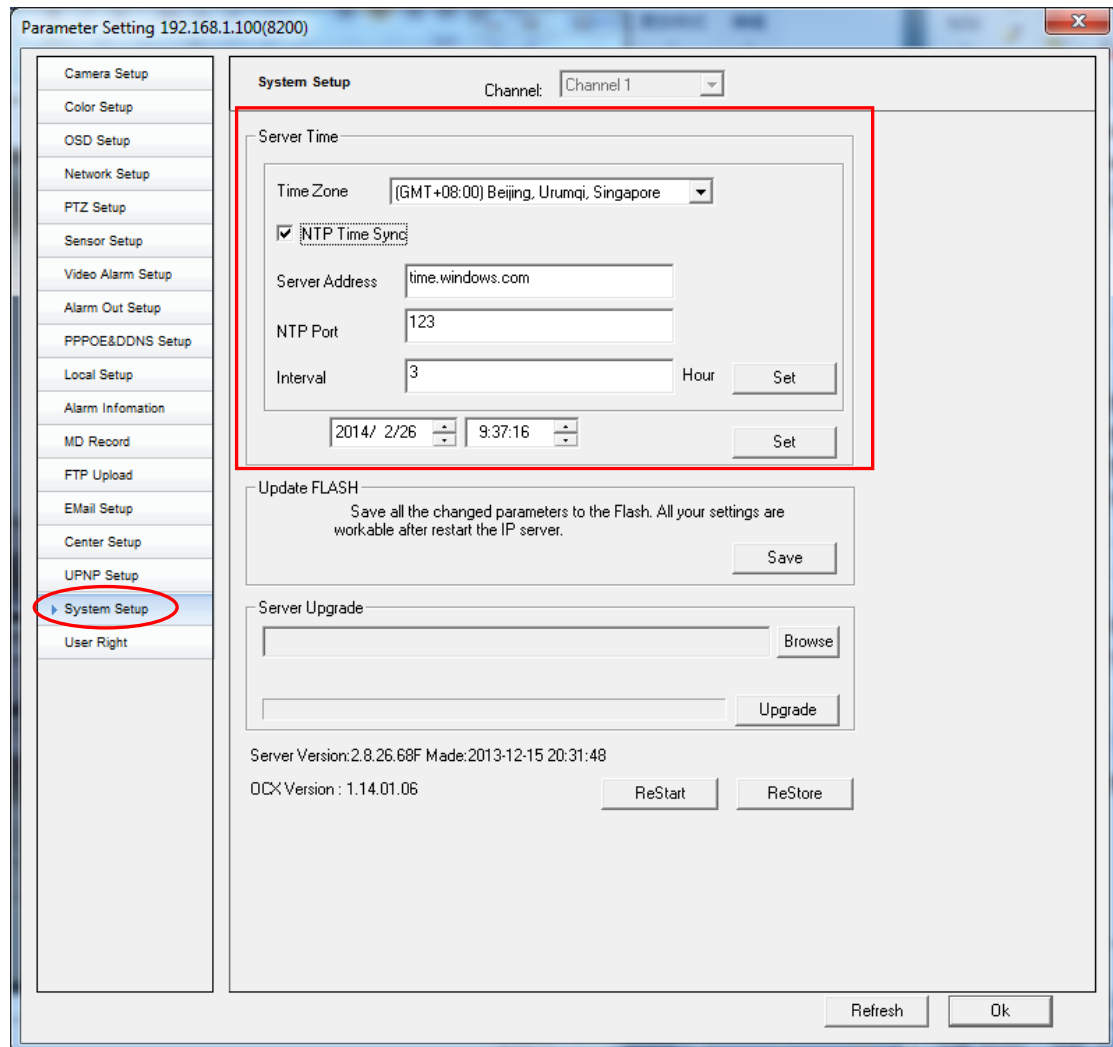

Figure 4-10-1 Time correction

## 4.10.2 Server Upgrade

When the IP Camera is required to update and upgrade, open [Setting] → [System Setup]; the system upgrading process is as follows:

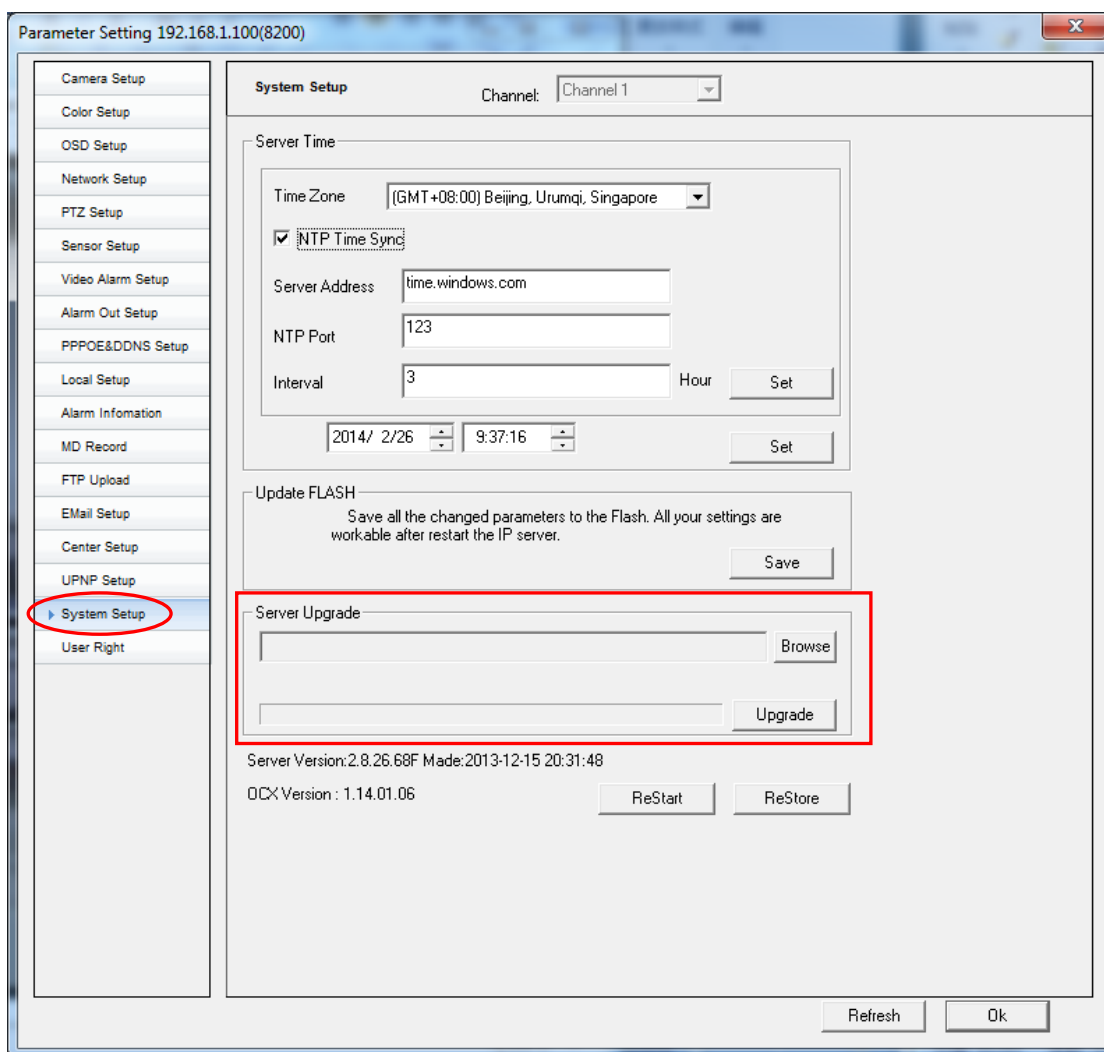

Figure 4-10-2 System upgrade

**Step I:** click [Browse] button, and show as Figure 4-10-2

**Step II:** select upgrade document, and show as Figure 4-10-3

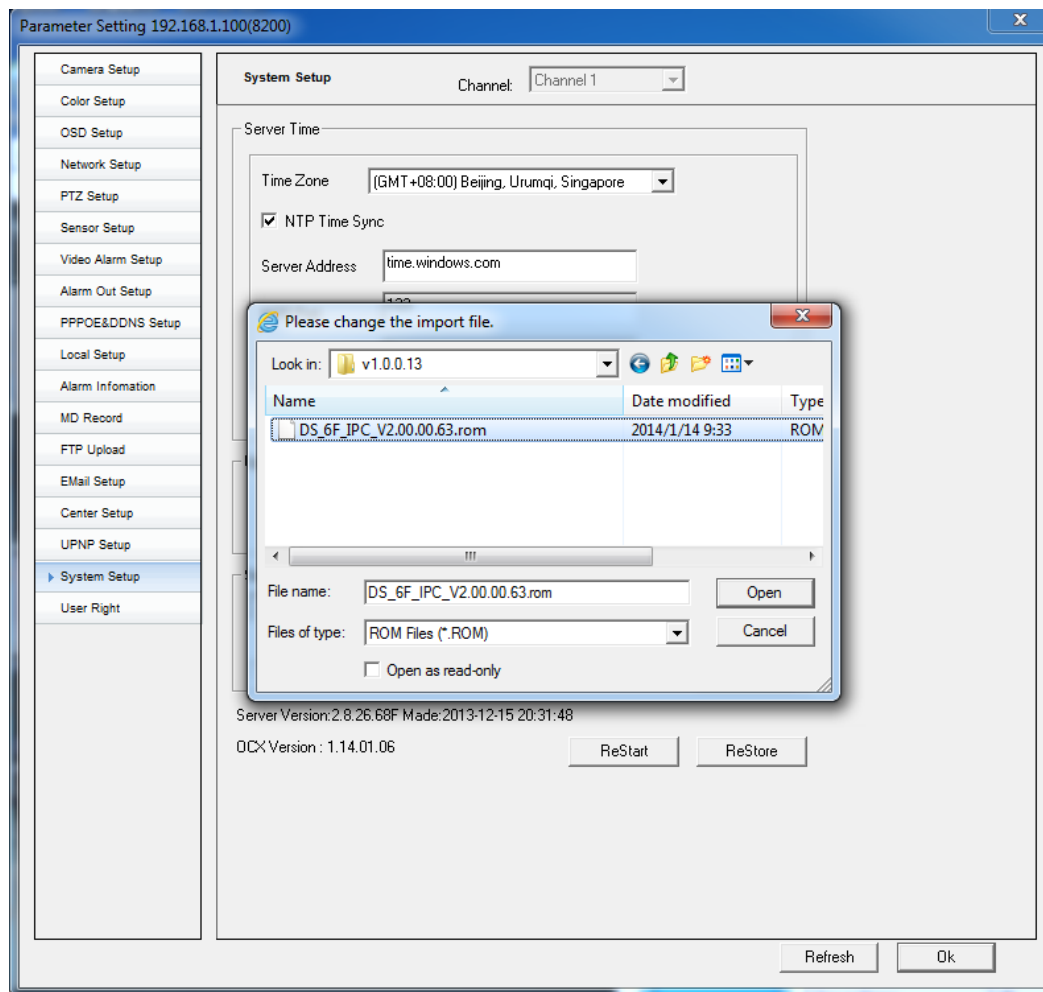

Figure 4-10-3 Browse file

**Step III:** click [Upgrade], and wait for the completion of the server upgrade



**Note:**

- **Before upgrading, please contact with our technician, and upgrade it under the guidance +++\* of the technician**
  - **The network cannot be disconnected during the upgrading process**
  - **The power supply of the IP Camera must be stable during the upgrading process**
- After completion of upgrading, the UP Camera will be restarted automatically; before re-running the system, do not perform any operation**

### 4.10.3 Store parameter

Open [Seting setting] → [System setting], click “Save” in the [Updata Flash] to store the modified parameter to Flash of the server; if the step is not followed, the original set parameter will be used still when the system is restarted.

Note: after modifying [Seting], when the [Seting] is closed, it will prompt “Store Flash or not”; the step is the same as the parameter storage in the [System Setup]

### 4.10.4 System information

Open [Setting] → [System Setup], check [Current server version], [OCX version], and show as Figure 4-10-4:

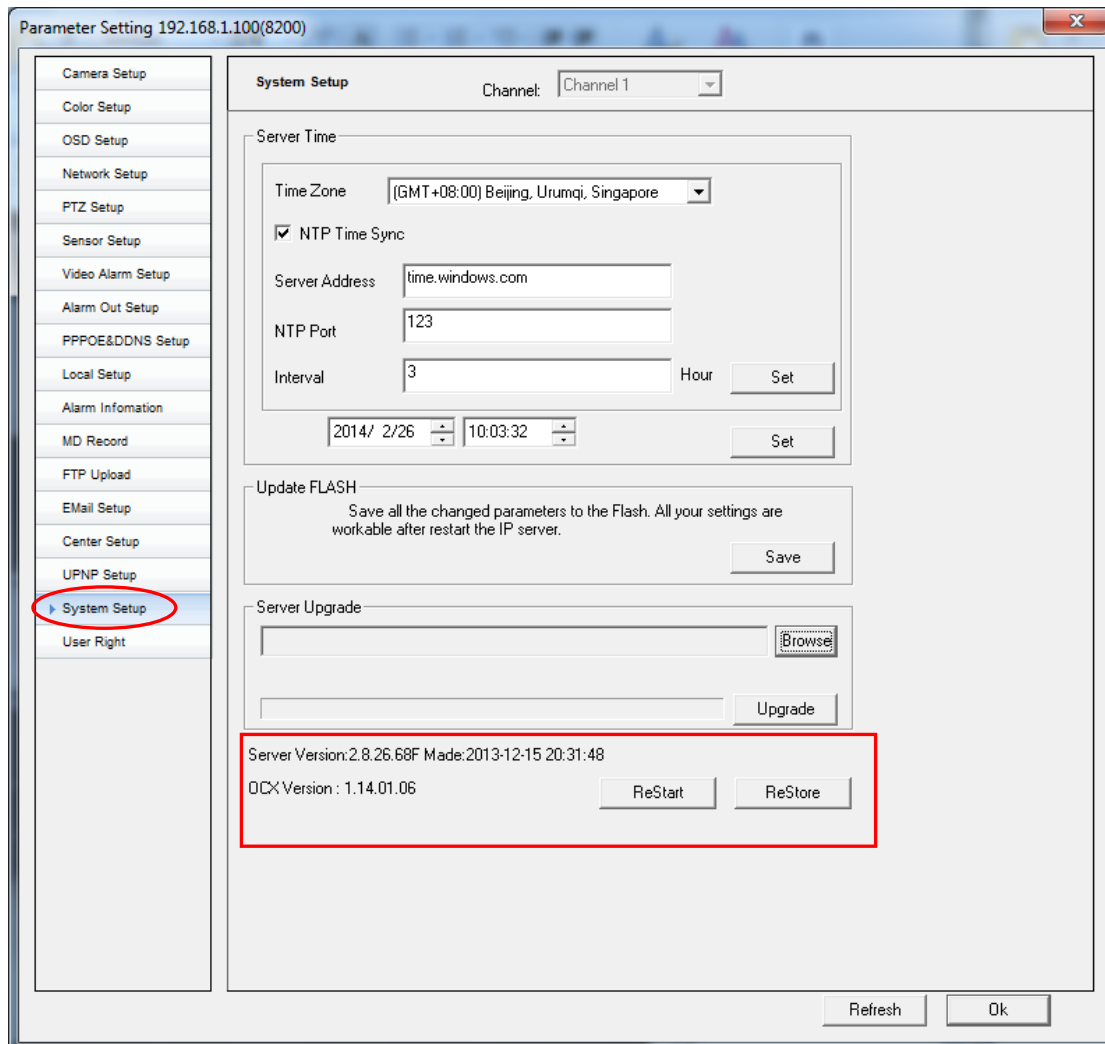

Figure 4-10-4 System setting

### 4.10.5 System restart

Open [Setting] → [System Setup], click [Restart] to restart the software

### 4.10.6 Restore factory

Open [Setting] → [System Setup], click [Restore], and restore all parameters except for network parameter and user right to be ex-factory value.

## 4.11 User Right

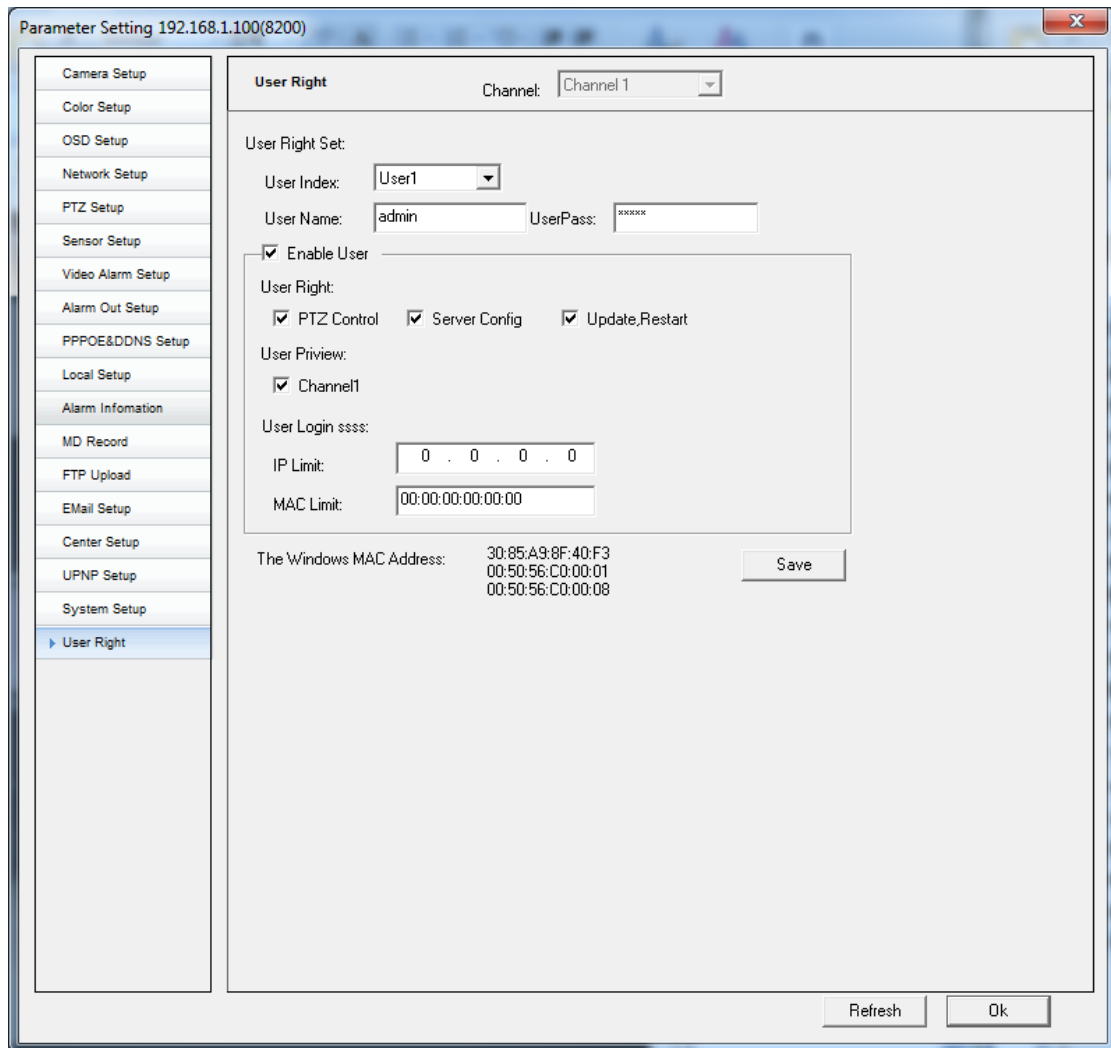

4-11-1 User right setting

The server supports five users at most. Every user can set independent right (user 1-user 6); **the admin user right cannot be modified.**

### Setting step:

**Step I:** open [Seting] → [User Right], show as Figure 4-11-1, click the pull-down optional box of [User Index] once, and select user (user 1-user 6 are optional)

**Step II:** set [UserName], [UserPass]

**Step III:** tick [Enable User]

**Step IV:** set user right

[PTZ Control, Server Config, Upgrade,Restart] are optional

[User Prview] is optional

[User Login ssss] defines the login of IP and MAC; fill 0 so that any address is allowed.

## 4.12 Record Management

### 4.12.1 Mobile disk recording

The IP Camera supports the built-in SD card and the built-out USB mobile disk recording; the maximum supporting capacity can reach 64 G.

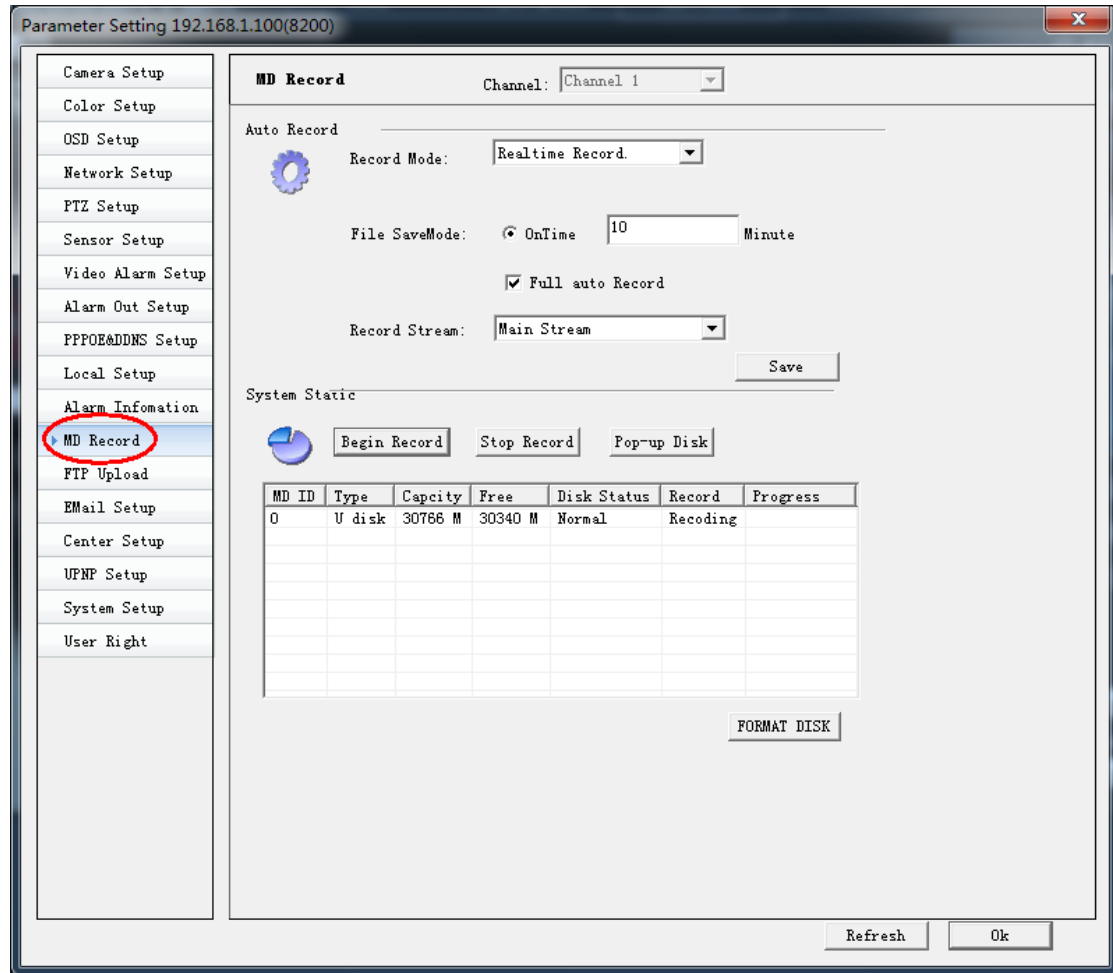

Figure 4-12-1 Mobile disk recording

#### Setting step of disk recording



**Note:** This series of product does not support the hot plug of the mobile disk; therefore, when the mobile disk recording is applied, please insert SD card or USB mobile disk firstly and then charge the camera; when the SD card is taken off, please unload the mobile disk at first.

**Step I:** insert the SD card to the IP Camera SD card interface or connect the built-out USB interface to the mobile disk

**Step II:** open [Seting] → [MD Record]

Select recording method from the recording setting:

There are three recording methods optional: [Realtime Record], [No Realtime Record], [Alarm Record]

**Step III:** select file packaging method:

Method I: package according to the file size, wherein the integer of the setting scope is 1-50 M;

Method II: package according to the recording time, wherein the integer of the setting scope is 1-10 minutes;

**Step IV:** [Full auto Record] can choose the record covering, tick represents that it is used

**Step V:** select the code stream required to record: select the main code stream or the sub-code stream

**Step IV:** click [Save], and record the stored equipment according to the corresponding setting

**If [MD Record] is not set, and IP Camera is equipped with the mobile disk, the recording will be automatically started when the IP Camera starts up**

### **Unload of mobile disk**

**Step I:** click [Stop Record] once

**Step II:** click [Pop-up Disk]

**Step III:** pull up SD card or USB mobile disk

### **Formatted mobile disk**

**Step I:** click and select mobile disk once

**Step II:** click [Format Disk] once

**Step III:** wait for formatting the mobile disk, click [Refresh] and check the state of the mobile disk

## **4.12.2 IE record playback**

Select [**Playback**] from the IE interface; playback the local recording document at the record playback page; search, playback and download the record file recorded by the Seting mobile disk. Shown as Figure 4-12-2

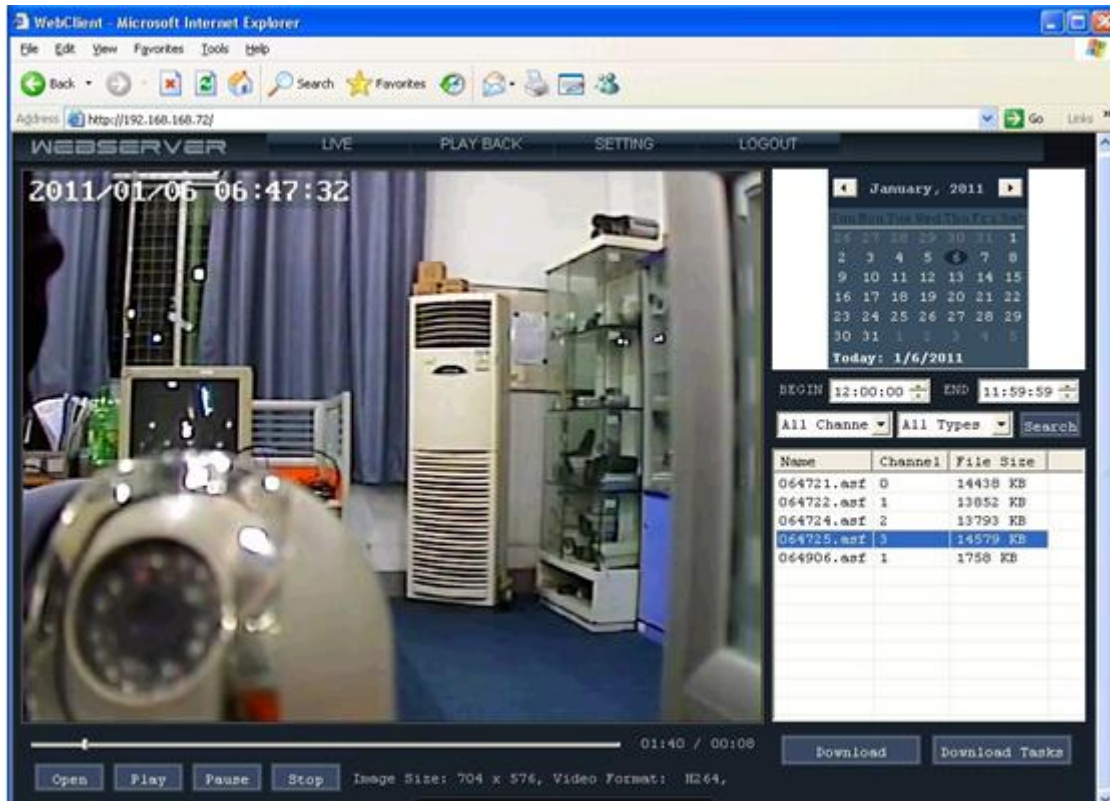
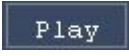

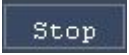

Figure 4-12-2 IE playback interface

**Introduction of interface function**

	<p>Setting of time section of record searching</p>																		
<table border="1"> <thead> <tr> <th>Name</th> <th>Channel</th> <th>File Size</th> </tr> </thead> <tbody> <tr> <td>064721.asf</td> <td>0</td> <td>14438 KB</td> </tr> <tr> <td>064722.asf</td> <td>1</td> <td>13852 KB</td> </tr> <tr> <td>064724.asf</td> <td>2</td> <td>13793 KB</td> </tr> <tr> <td>064725.asf</td> <td>3</td> <td>14579 KB</td> </tr> <tr> <td>064906.asf</td> <td>1</td> <td>1758 KB</td> </tr> </tbody> </table>	Name	Channel	File Size	064721.asf	0	14438 KB	064722.asf	1	13852 KB	064724.asf	2	13793 KB	064725.asf	3	14579 KB	064906.asf	1	1758 KB	<p>Search result and double click the recording file to play</p>
Name	Channel	File Size																	
064721.asf	0	14438 KB																	
064722.asf	1	13852 KB																	
064724.asf	2	13793 KB																	
064725.asf	3	14579 KB																	
064906.asf	1	1758 KB																	
<p>Download</p>	<p>Select the file to be downloaded and then click this button to download the recording file</p>																		
<p>Download Tasks</p>	<p>When multiple files are downloaded at the same time, click this button and check the download task</p>																		
<p>Open</p>	<p>Click this button, browse and play the downloaded record file</p>																		



	Click the button and play the recording file
	Click this button, and pause the playing of the recording file
	Click this button and stop playing the recording file

### 4.12.3 Client recording playback

For the detailed introduction of the client recording playback, please refer *Using Manual of Video Monitoring Management Software*

## 5 Wireless Access

### 5.1 Access through Wifi

#### 5.1.1 Configuration of wireless parameter of wireless router

Log in the wireless router and select wireless parameter; (take TP-LINK wireless router as an example): configure SSID number, encryption mode and password.

#### 5.1.2 Configuration of wireless parameter of camera



**Note: Before setting WIFI parameter, please confirm that your camera has been equipped with the WIFI net card and antenna**

Open [Seting]-[Wireless setting], wherein the wireless state selects [Static IP] or [DHCP] mode. Two methods can configure the wireless setting.

Method I:

Search wireless configuration: click the setting interface [search wireless] once, and search all wireless ID, encryption mode, signal intensity, and MAC address of wireless router within the current signal scale; double click and select the wireless ID required to add; and then manually configure wireless IP address, gateway, sub-net mask, DNS, working mode, and encrypted content; show as Figure 5-1-2

[IP address]: set any one network IP address which is not conflict with the LAN

[Working mode]: select “managed”

[Encrypted content]: the wireless password must be in accordance with the PSK password for wireless router.

Method II:

Manually add wireless configuration: manually configure wireless IP address, gateway, and subnet mask, DNS, ESSID, working mode, character format, and encrypted content, show as Figure 3-4-2 [IP address]: set any one network IP address which is not conflict with the LAN.

[ESSID]: the name of the wireless network is the same as the wireless router;

[Working mode]: select “managed”

[Encrypted content]: the wireless password must be in accordance with the PSK password for wireless router.

[Character format]: select HEX or ASCII encrypted character format according to the encryption mode of the wireless router

[Encryption mode]: select “WPAPSK-AES” or “WPA2PSK-AES”

After setting above parameter through method I or method II, click [Setting]-[Closing]; select [Yes] from the popped storage parameter dialog box.

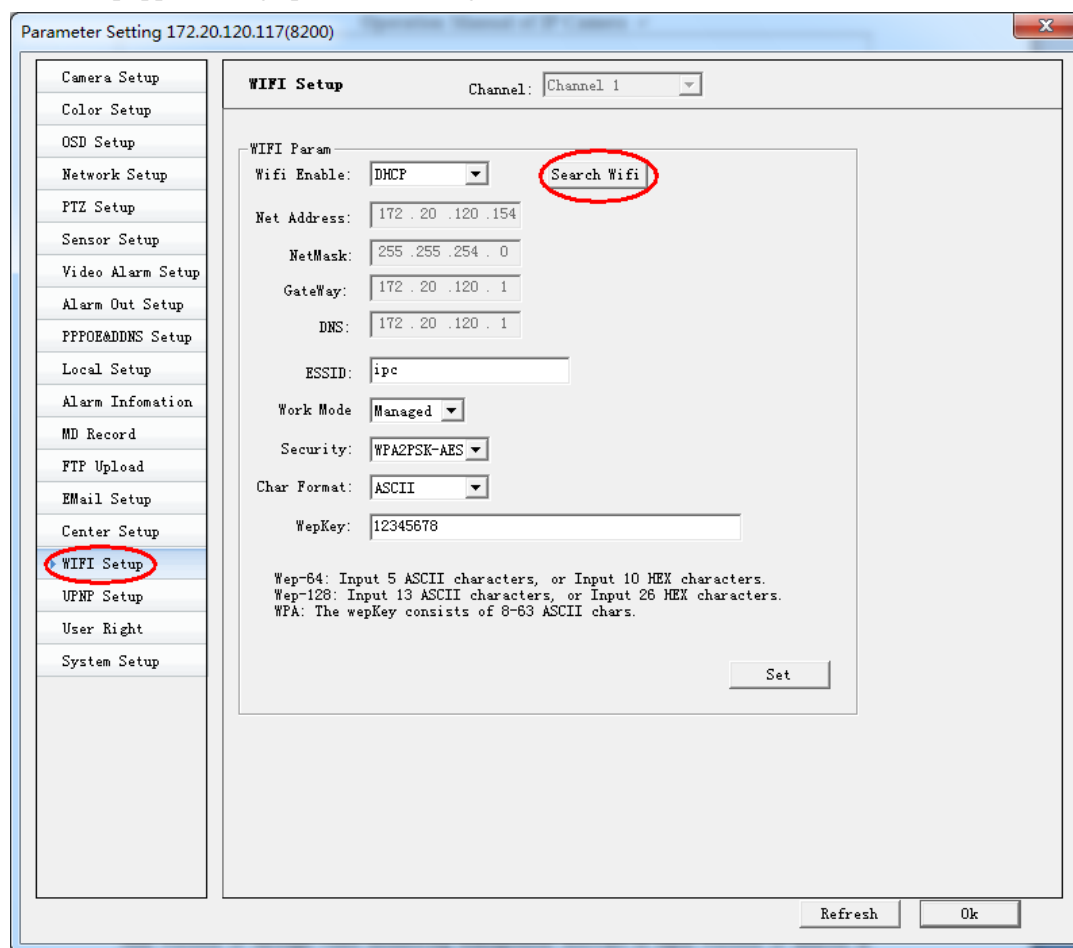

Figure 5-1-2 Wireless setting interface

### 5.1.3 Access camera through wireless IP

Add wireless IP through video monitoring management software or input wireless IP address at the IE address bar directly so as to connect the camera. As for the method of adding the camera to the client, please refer to **“Chapter 3.3 Access through client”**

## 5.2 Access through mobile phone

### 5.2.1 Configuration of camera and mobile phone parameter

Open [Setting setting]-[Wireless setting]; set the access port of the mobile phone; the default value is 15961; it is shown as Figure 5-2-1:

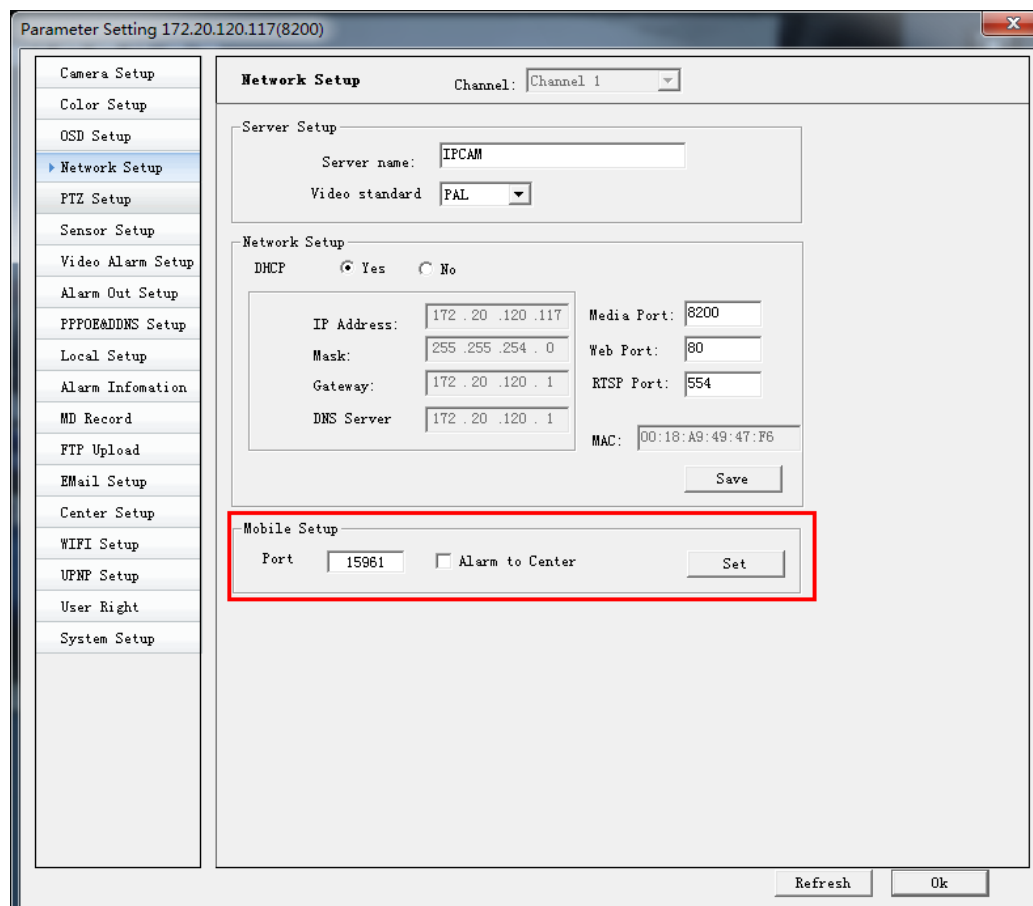

Figure 5-2-1 Mobile phone access setting

### 5.2.2 Mobile phone access

When the mobile phone accesses, set the wireless network of the mobile phone to the same one network section as the IP Camera if it is **LAN access**; set the wireless network of the mobile phone to be the accessible public network if it is **WAN access**. As for the installation and access of the mobile phone software, please refer to the *Instruction Book of Mobile Phone Monitoring Software* attached by the light disk matched at random, and the mobile phone monitoring software.

## 5.2.3 Mobile phone alarm

Set [Alarm uploading], wherein we call “mobile phone alarm uploading” as [Mobile phone Push Alarm] function; tick and use the [Alarm uploading center], and the network of the IP Camera can access the public network; meanwhile, the mobile phone software is required to open the Push Alarm; please refer to *Instruction Book of Mobile Phone Monitoring Software* about the operation instruction of the mobile phone. When the IP Camera triggers alarm, the mobile phone will receive the alarm prompt information and check video in real time.

## 5.3 Access through 3G

### 5.3.1 3G parameter setting



**Note: Before setting 3G parameter, please confirm that your camera has been equipped with 3G net card and antenna**

Open [Setting]-[Wireless setting]; select “wireless setting” item; select [Use] in the right side [3G parameter] bar, and select type of **3G** card. At present, support telecom **3G** card: EVDO, Unicom 3G card; **WCDMA**.

Click [Setting] and store parameter. The first dialing time is about 1 minute. After dialing successfully, it can be used; if the dialing of 3G card is successful, the 3G state will show “UP”, and the IP address will show the obtained IP address.

### 5.3.2 3G access

#### I. Telecom 3G access

If you use the telecom network, access through the IP address obtained by 3G dialing or directly through IE or client.

#### II. Unicom 3G access

If you use the Unicom network, access through the IP address obtained by 3G dialing or directly through IE or client.

**Note: For the 3G network of Telecom or Unicom of a part of areas will shield the defaulted 80 port, it is required to modify the Web port, thus the 3G access can be passed correctly; As for the modification of Web port, please refer to “Chapter 4.2.1 Fixed IP”**

## 6 WAN Access

### 6.1 Access through DDNS

#### 6.1.1 DDNS setting

According to user's demand, if user is required to access IP Camera through the domain name, set it by selecting the DDNS supported by IP Camera; at present, five types of DDNS servers are supported, which are: www.3322.org; www.dyndns.com; www.nightowlivr.com; www.on-ip.com; MyEYE (MyEYE is DDNS provided by our company for free, which is www.dvripc.cn; www.dvripc.net; "cn" is the domain name of domestic server; "net" is domain name of foreign server) . For the detailed settings of the MyEYE domain name, please refer to "Appendix II MyEYE domain name"

Log in the website of the domain name analyzing sever and register a domain name; then access the IP Camera through the registered domain name. MyEYE is not required to register; if IP Camera is indirectly connected to the public network through the router, it is required to perform the port mapping on the router or use the UPNP port mapping (it needs that the router starts the UPNP function).

**As for the detailed configuration process of the port mapping, please refer to "Appendix I Port mapping method"**

The step of using DDNS is as follows:

**Step I:** open [Seting setting] → [PPPOE&DDNS setting], tick  启用DDNS (Enable DDNS) and use DDNS, show as Figure 6-1-1.

**Step II:** select DDNS service provider, and then select the type of the DDNS server address

**Step III:** default the DDNS server port as 80; not modify if the address of the server is 80 port.

**Step IV:** input customized domain name, user name, and password.

**Step V:** set the update cycle of domain name, wherein the minimum cycle is 30 seconds, and the maximum cycle is 2 hours.

**Step VI:** after confirming that the configuration is right, click [Setting], quit and store.

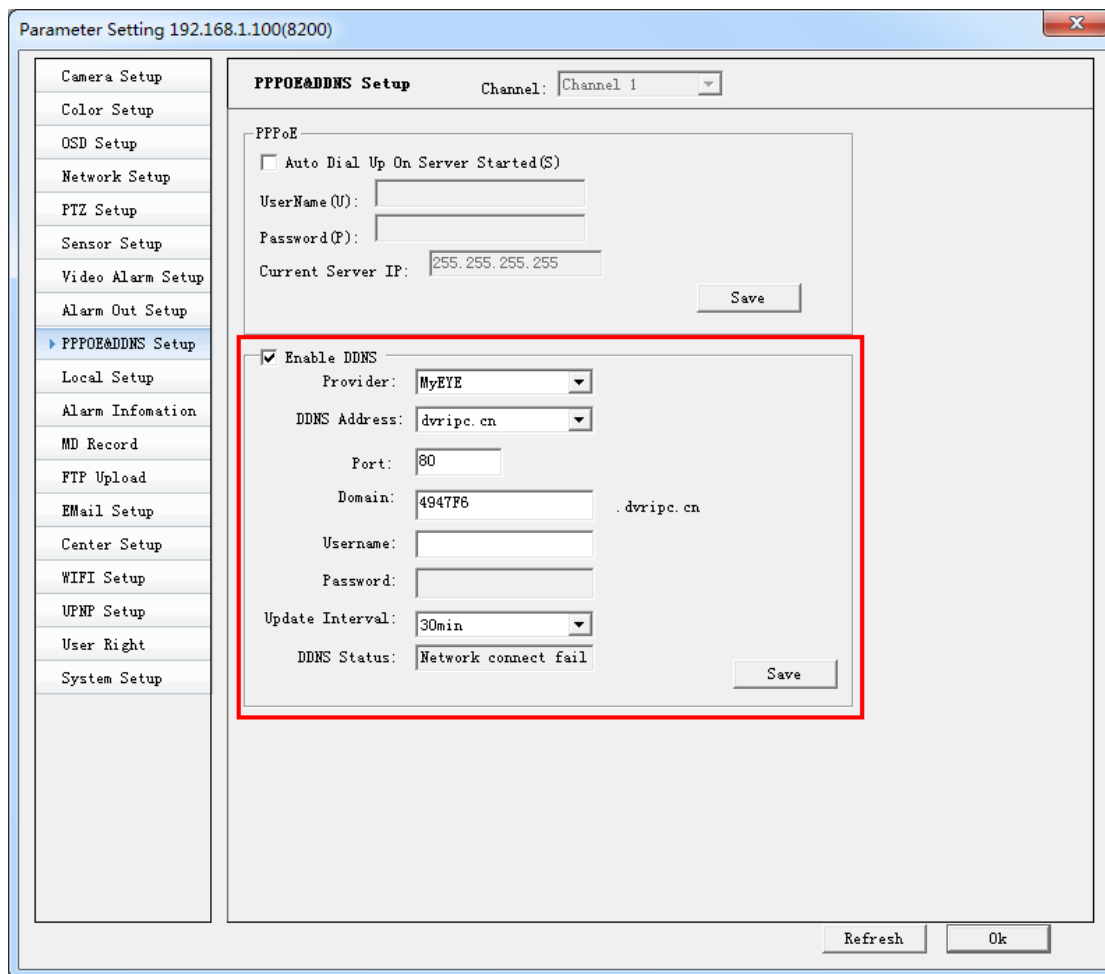

Figure 6-1-1 DDNS setting

## 6.1.2 DDNS domain name access

Through the video monitoring management software, add domain name or directly input domain name in the IE address bar so as to connect to the camera. As for the method of adding domain name to the video monitoring management software, please refer to **Chapter 3.3 Client access**

## 6.2 Access through P2P

**Configure P2P according to the ex-factory demand of user, use the spot-to-spot mapping technology of the P2P cloudy server, and support Telecom/China Netcom/Unicom/Mobile internet/Cable network/Railcom/GWBN/ FTTX LAN, and other various networks.**

By applying the P2P technology to IP Camera, the IP Camera is added with the following characteristics:

1. Plug and play
2. Check and remember the free domain name of IP Camera only; if the third party software is successfully set, it is not required to remember any domain name or IP of the camera, watch it

easily. All problems can be solved by network wherever and whenever.

3. P2P technology makes the IP Camera suffer from the neck restriction between different network operators, and can reach the mutual smooth communication among Telecom, Railcom, GWBN, China Netcom, and FTTX LAN.

4. Reduce the band width occupied by the WAN access of IP Camera

Add domain name through the video monitoring management software or directly input domain name at IE address bar so as to connect to the camera. The P2P transmission method can support the mobile access at the same time.

The P2P cloudy service of our company is bound with the MyEYE domain name; the machine with ex-factory set P2P is only required to set the MyEYE domain name instead of P2P separately; through the domain name, IP Camera can be accessed easily

As for the detailed setting of the MyEYE domain name, please refer to “Appendix MyEYE domain name”

## Appendix I Port mapping method







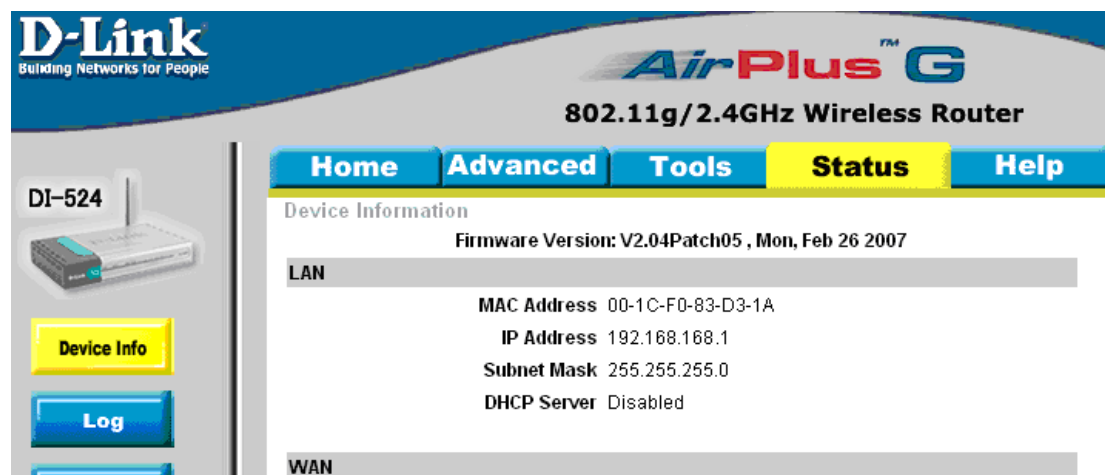





















Note: the description below takes the configuration interface of the TP-LINK router (model is TL-R410) as an example, the configuration interface of the other router may be different.

**Step I:** firstly, select internet access method from the “setup guide” of the network router where the IP Camera locates.

**Step II:** set “network parameter” of router, wherein the Figure below is the parameter setting of LAN port, it includes the mask and gateway of LAN; the IP address 192.168.168.1 is the gateway of the internal network.



**Step III:** perform the port mapping in the option “Transfer rule” →”Virtual server” of the router. The port number of the IP Camera is 80, 8200, 554; IP is 192.168.1.90; select All or TCP in the protocol and select use; after storing corresponding setting, realize the port mapping function, show as the Figure below

Virtual Server List				
Name	Private IP	Protocol	Schedule	
<input type="checkbox"/> Virtual Server FTP	0.0.0.0	TCP 21 / 21	Always	 
<input type="checkbox"/> Virtual Server HTTP	0.0.0.0	TCP 80 / 80	Always	 
<input type="checkbox"/> Virtual Server HTTPS	0.0.0.0	TCP 443 / 443	Always	 
<input type="checkbox"/> Virtual Server DNS	0.0.0.0	UDP 53 / 53	Always	 
<input type="checkbox"/> Virtual Server SMTP	0.0.0.0	TCP 25 / 25	Always	 
<input type="checkbox"/> Virtual Server POP3	0.0.0.0	TCP 110 / 110	Always	 
<input type="checkbox"/> Virtual Server Telnet	0.0.0.0	TCP 23 / 23	Always	 
<input type="checkbox"/> IPsec	0.0.0.0	UDP 500 / 500	Always	 
<input type="checkbox"/> PPTP	0.0.0.0	TCP 1723 / 1723	Always	 
<input type="checkbox"/> DCS-900,DCS-1000	0.0.0.0	TCP 80 / 80	Always	 
<input type="checkbox"/> DCS-2000,DCS-5300	0.0.0.0	TCP 800 / 800	Always	 
<input type="checkbox"/> DCS-3120	0.0.0.0	UDP 5002-5003 / 5002-5003	Always	 
<input checked="" type="checkbox"/> DVS	192.168.168.72	TCP 8200 / 8200	Always	 
<input checked="" type="checkbox"/> DVS	192.168.168.72	TCP 80 / 80	Always	 

Through the setting above, the 80, 8200, 554 port mapping of the router is mapped to 192.168.190 of IP Camera, thus the 80, 8200, 554 port of the router is access 192.168.168.72.

Note: the port number of the IP Camera cannot conflict with the other port number; if the web administration port number of the router is 80, it is required to modify the port number of the router or the IP Camera so as to avoid conflict.

## Appendix II MyEYE



**Note: MyEYE is the latest free dynamic secondary domain name of our company which solves the problems that the Setting monitoring requires fixed IP and the update of the domain name is slow; the new generation of domain name is possessed of quick refresh time and stable domain name and supports the uniform management of multiple domain name; it is not required to register user. Wherein the dvrip.cn belongs to the domestic domain name server (excludes Hongkong, Macau, Taiwan); dvrip.net belongs to the foreign domain name server.**

**Step I:** log in client software or IE preview interface-->open [Setting] →[PPPOE&DDNS Setup]-->Enable DDNS-->select MyEYE DDNS network provider. Shown as Appendix 2

**Step II:** input domain name on the DDNS setting interface, wherein the default domain name is the last 6 digit numbers of MAC address; click “setting” and store. The MyEYE not requires the user name and password.

**Step III:** set UPNP or set port mapping on the router. As for the port mapping method, please refer to “Appendix I Port mapping method”

**Step IV:** try to use the just applied domain name to access IP Camera; if it can be accessed normally, it shows that you have been set successfully. As for the method of adding access to domain name, please refer to “Section 6.1.2 DDNS domain name access”



If you are required to search the online state of the domain name, please consult our technology.

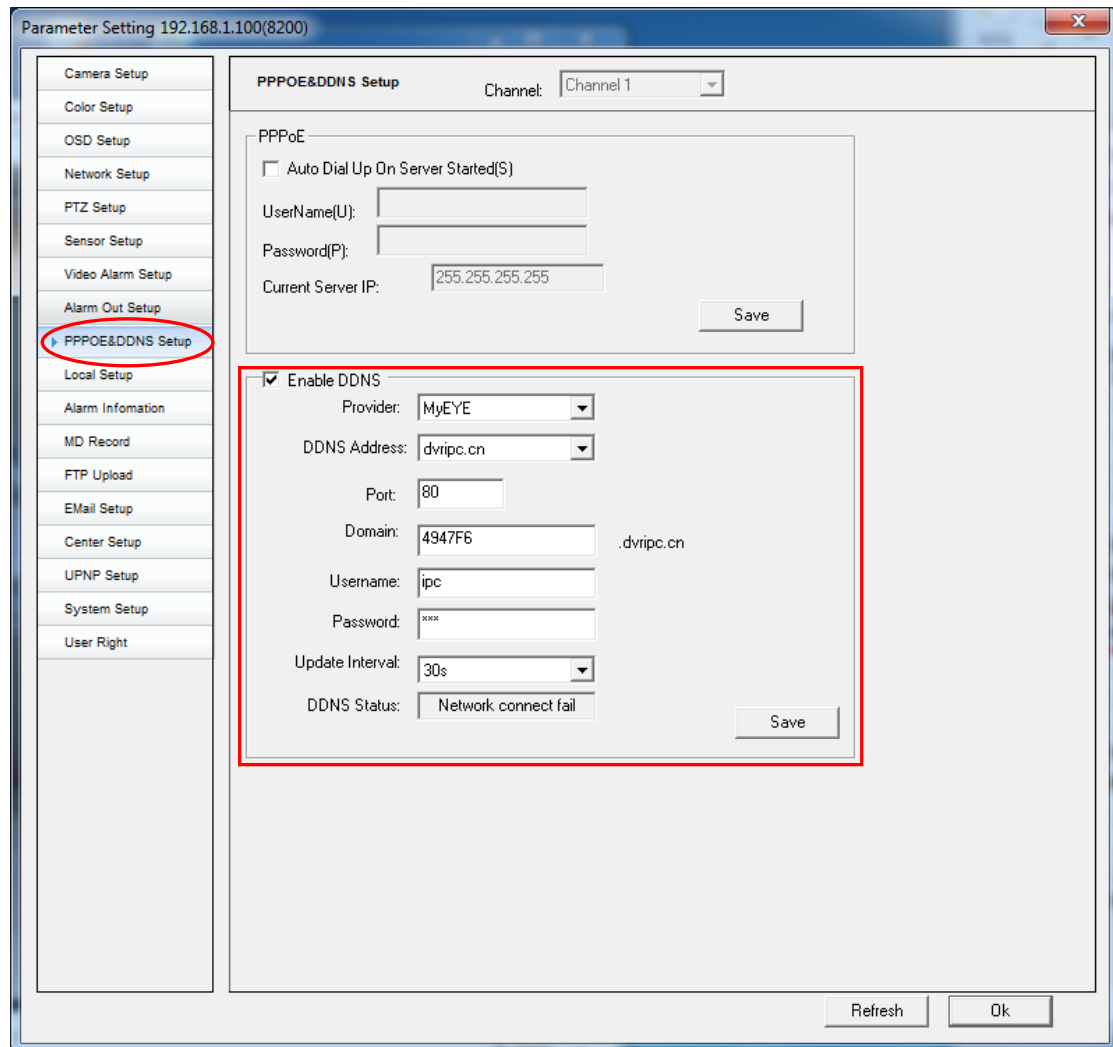

Figure Appendix 2 MyEYE set

## Appendix III Ex-factory default parameter of equipment

### 1 Network parameter

#### 1) Network video server and default parameter of IP Camera

Parameter	Default
IP address	DHCP(Direct Connect IP:192.168.1.100)
Subnet mask	255.255.255.0

Gateway	192.168.1.1
DNS	8.8.8.8
Data port	8200
web port	80
RSTP port	554
Mobile phone access port	15961

## 2. User name and password

Parameter	Default
User name	admin
Password	admin

# Appendix IV Common troubleshooting instructions

**Q: How to quickly connect the new machine and preview pictures?**

A: Please read *Quick Operation Manual of IP Camera* before using the equipment

**Q: Why the searching tool for opening the IP Camera cannot search the equipment IP?**

A: Reason 1: the IP Camera is not connected with the power supply or does not use the power adaptor meeting the standard;

Solution: supply power to the equipment by using the standard power adaptor of the IP Camera, check whether the power indicator lamp (PWR) of the equipment is lighted, and whether the equipment running light (RUN) is flashed normally.

Reason 2: the network wire is bad or the network wire is too long;

Solution: manufacture the cable again, wherein the length of single network cable shall not exceed 80 meters; try to use the more than five types or six types of shield network cables with good quality; after connecting the network cable, please check whether the network connection indicator lamp is lighted.

Reason 3: the computer firewall stops the searching tool;

Solution: before opening up the searching tool, please try to close the firewall of the computer temporarily; after normally connecting the equipment, open up the firewall of the computer.

Reason 4: The modified network address of the equipment may cause that the IP address and the gateway of the equipment are not in the same one network section, or the IP Camera and your PC machine are not in the same one VLAN.

Solution: press the RST reset key of the equipment under the charging state for about 5 seconds and set free after the network light is turned off, thus the equipment will be restored to the ex-factory default parameter. The equipment default ex-factory IP address is **192.168.1.100**; if the IP Camera and the access computer are not in the same one VLAN, please contact the network

administrator to open up the access right.

**Q: Why the picture is dim or has color cast after connecting the picture?**

A: Reason 1: the lens is dirt, and the lens hasn't adjusted the focal length well or the used lens is not accordance with the IP Camera;

Solution: clean the lens carefully by using a professional lens cloth, re-adjust the focal length of the lens; please use the megapixel lens if it is the megapixel IP Camera with.

Reason 2: the brightness, contrast ratio, definition and color parameter are not well adjusted;

Solution: fine adjust the brightness, contrast ratio, definition and color parameter again according to the specific installing environment.

**Q: Why the IP camera cannot be accessed through internet?**

A: Reason 1: there is no access environment of internet or no access right.

Solution: please install the internet access environment in advance, e.g. open up the ADSL network or fixed IP address of internet; if there is no network access right, please contact with the network administrator to open up the relevant access right.

Reason 2: there is not well set network parameter, port mapping and DDNS;

Solution: the correctly set network parameter of the IP Camera includes IP address, subnet mask, gateway, DNS and network access port so as to ensure that your equipment network address can be normally connected with the internet; normally configure the port mapping, apply and configure correct DDNS domain name.

**Q: Why the video image is not smooth or has big delay when the IP Camera is accessed through internet?**

A: Reason 1: the network bandwidth for uploading or downloading is not enough;

Solution: optimize or promote the uploading bandwidth of the IP Camera access and improve the downloading bandwidth of the access port network; reduce the coding rate and frame rate of IP Camera.